

1.0 SCOPE

1.1 Purpose

This specification establishes the general requirements for motherboard (AKA fixed/backplane) style connectors and daughterboard (AKA free) style high-reliability six-row 2-mm pitch cPCI™ style printed wiring board (PWB) connectors that utilize the Hypertac™ wire basket socket contact system. The connectors are designed to perform reliably in severe environments that include shock, vibration, and temperature extremes. Two styles for each connector are offered: style A for use with the multi-purpose center (MPC) polarization feature, and style B without.

1.2 Application Notes

This document also includes application notes (Section 6.1) to provide users with assistance in properly applying and handling these connectors.

1.3 Goddard Part Number (See Table III)

Connectors procured in compliance with this specification shall be identified by a Goddard part number having the following form:

311P822 – (X)XX – XXX – X(X) – D(X)

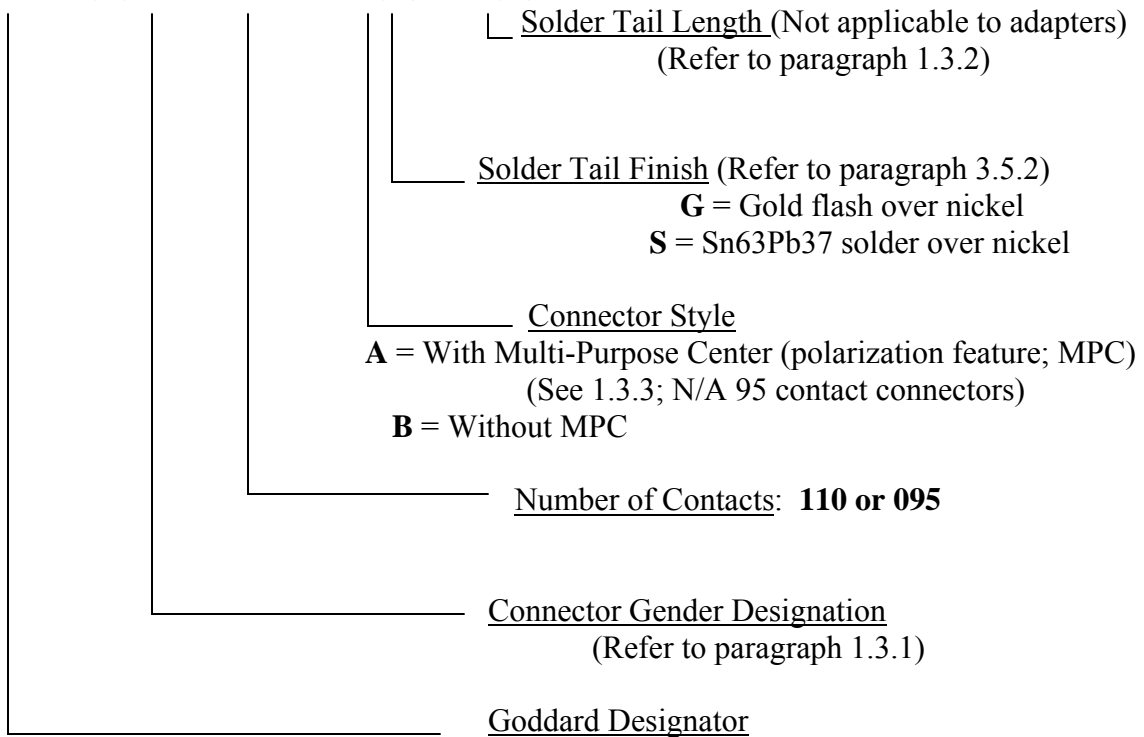

1.3.1 Connector Gender Designations

FC = Female Connector/Fixed Motherboard Backplane with Socket Contacts.

MC = Male Connector/Free Daughterboard with Pin Contacts.

MA = Male Adapter, mates 311P822 male daughterboard pin connector (designation MC) to commercial cPCI™ fixed motherboard connector (see note 6.1.6).

FA = Female Adapter, mates 311P822 female motherboard socket connector (FC) to commercial cPCI™ free daughterboard connector (see application note 6.1.6).

FFA = Female-to-Female Adapter, mates two 311P822 male daughterboard pin connectors (MC) together (see application note 6.1.6).

1.3.2 Connector Solder Tail Length Designations

Designation	FC Backplane Motherboard Connector Tail Length	MC Daughterboard Connector Tail Length
D	5.50 mm (.216")	3.12 mm (.123")
D1	Reserved	Reserved
D2	16.0 mm (.630")	Reserved
D3	Reserved	Reserved
D4	4.22 mm (.166")	4.2 mm (.166")

1.3.3 Multi Purpose Center (MPC) Keying

Optional polarization keys must be ordered separately. **See Table III for part numbers.** A male connector requires a male key. A female connector requires a female key.

1.3.4 Connector Solder Holding Fixtures For soldering fixture part numbers, see Table III.

2.0 **APPLICABLE DOCUMENTS**

2.1 **Issues of Documents**

The following documents, of the issues in effect on the date of invitation for bids or requests for proposals, form a part this specification to the extent specified herein:

Military

MIL-DTL-55302 Connectors, Printed Circuit Subassembly and Accessories

MIL-STD-202 Test Methods for Electric and Electrical Component Parts

MIL-STD-1285 Marking of Electrical and Electronic Parts

MIL-M-24519 Molding Plastics, Electrical, Thermoplastic

Industry

EIA-364	Electrical Connector/Socket Test Procedures Including Environmental Classifications
IEC 60297-3-101	International Electrotechnical Commission Specification for Mechanical Structures for Electronic Equipment, dimensions of mechanical structures of the 482.6 mm (19 in.), series part 3-101, sub-racks and associated plug-in units
IEC 61076-4-101	International Electrotechnical Commission Specification for Connectors, with assessed quality, for use in DC low-frequency analog and in digital high-speed data applications Part 4, Printed Board Connectors, Section 101, detail specification for two-part connector modules having a basic grid of 2.0 mm for printed boards and backplanes
PICMG 2.0 R3.0	PCI Industrial Computer Manufacturers Group (PICMG™) Spec for Compact Peripheral Component Interconnect (cPCI™)
ASTM-B194	Standard Specification for Copper-Beryllium Alloy Plate, Sheet, Strip and Rolled Bar
ASTM-B197	Standard Specification for Copper-Beryllium Alloy Wire
ASTM-B488	Standard Specification for Electrodeposited Coatings of Gold for Engineering Uses
ASTM-D5138	Liquid Crystal Polymers, Standard Specification for
ASTM-E595	Material from Outgassing in a Vacuum Environment, Total Mass Loss and Collected Volatile Condensable, Standard Test Method
SAE-AMS-QQ-N-290	Plating, Nickel
SAE-AMS-P-81728	Plating, Tin Lead (Electrodeposited)
SAE-AMS-2418	Plating, Copper
SAE-AS39029	Contacts, Electrical Connector, General Specifications for
IPC/EIA J-STD-002	Solderability Tests for Component Leads, Termination, Lugs, Terminals and Wires
IPC/EIA J-STD-006	Requirements for Electronic Grade Solder Alloys

NASA

GSFC EEE-INST-002	Instructions for EEE Parts Selection, Screening, Qualification, and Derating
-------------------	--

3.0 REQUIREMENTS

3.1 General

The individual item requirements shall be in accordance with the applicable specification herein. In the event of any conflict between requirements of this specification and the references cited herein, the text of this specification shall take precedence. However, nothing in this text shall supersede applicable laws and regulations unless a specific exemption has been obtained.

3.2 Ratings

The ratings for these connectors shall be as follows.

3.2.1 Derated Current

1 amp max. per contact at 70 °C derated to 0.25 amp max. at 120 °C.

3.2.2 Dielectric Withstanding Voltage

750 VRMS sea level.

3.2.3 Insulation Resistance

5,000 Megohms at 500 VDC.

3.2.4 Contact Resistance

20 milliohms per contact, max. as specified in IEC 61076-4-101.

3.2.5 Temperature Range

-65 °C to +125 °C.

3.3 Workmanship

The connectors and contacts shall be manufactured in such a manner as to be uniform in quality, and shall be free from cracked or displaced parts, sharp edges, burrs, corrosion, and other defects that will affect life, serviceability, or appearance.

3.4 Test Reporting and Data Recording

Test data shall be delivered with the connectors. Records of actual test data on all screened connectors shall be retained by the facility for a period of 5 years from the date of manufacture and shall be made available for inspection to the procuring activity within that duration if so requested.

3.5 Materials Requirements

3.5.1 Body Molding Material (Inserts and Pin Contact Module)

Connectors: 50% glass-filled liquid crystalline polymer, type GLCP-50F, in accordance with MIL-M-24519, or type LCP0120G50A43430 in accordance with ASTM-D5138.

Adapters and Keys: 30% glass-filled liquid crystalline polymer, type GLCP-30F, in accordance with MIL-M-24519, or type LCP0120G30A43430 in accordance with ASTM-D5138. The 50% glass-fill material used for connectors may also be used.

3.5.2 Contacts

Approximate contact size is 28 for type A copper alloy contacts in SAE-AS39029.

3.5.2.1 Pin Contacts

3.5.2.1.1 *Base Metal.* Beryllium copper in accordance with ASTM-B194, alloy 172.

3.5.2.1.2 *Finish.* Engagement (mating) area, plated with 50 microinches (μin) gold per ASTM-B488 over 50 μin nickel per SAE-AMS-QQ-N-290 over copper strike per SAE-AMS-2418. Tail: Finish G: Gold flash over nickel barrier. Finish S: Sn63Pb37 solder per IPC/EIA J-STD-006 over nickel barrier per SAE-AMS-P-81728 (finish S). The solder finish shall not be applied on the tail higher than the contact entry point into the connector body.

3.5.2.2 Hypertac™ Socket Contacts

3.5.2.2.1 *Body.* (Ring, ferrules, rear tail), brass, proprietary alloy.

3.5.2.2.2 *Finish.* Engagement (mating) area: Plated with 50 microinches (μin) gold per ASTM-B488 over 50 μin nickel per SAE-AMS-QQ-N-290 over copper strike per SAE-AMS-2418. Tail: Finish G: Gold finish over nickel barrier. Finish S: Sn63Pb37 solder per IPC/EIA J-STD-006 over nickel barrier per SAE-AMS-P-81728 (finish S). The solder finish shall not be applied on the tail higher than the contact entry point into the connector body.

3.5.2.2.3 *Wire.* Beryllium copper in accordance with ASTM-B197, alloy 172, overcoated with 50 μin gold per ASTM-B488 over 50 μin nickel per SAE-AMS-QQ-N-290.

3.5.2.2.4 *Shield.* Beryllium copper, in accordance with ASTM-B194, alloy 172, plated 50 μin gold per ASTM-B488 over 50 μin nickel per SAE-AMS-QQ-N-290. Shield terminations shall be solder-dipped with Sn63Pb37 solder per IPC/EIA J-STD-006.

Note: Cadmium or zinc platings, which are known to sublime in a hard vacuum, shall not be used. Use of pure tin plating or lead-free tin alloys is prohibited internally and externally. Use of tin-lead finishes is acceptable provided that the minimum lead content is 3%. All finishes shall be free from breaks, scratches, and other defects that will reduce the service of the connectors.

3.5.3 Soldering Fixtures. Soldering fixture materials shall be in accordance with Figures 17 and 18.

3.6 Electrical Requirements

3.6.1 Contact Resistance

When tested in accordance with paragraph 4.5, resistance measurement shall not exceed 20 milliohms maximum for 1 amp applied current. (See paragraphs 3.2.1 and 3.2.4.)

3.6.2 Low-Level Signal Contact Resistance

When tested in accordance with paragraph 4.6, measured resistance is not to exceed 20 milliohms (mΩ) at 100 milliamps (ma) applied current.

3.6.3 Dielectric Withstanding Voltage (DWV)

When tested in accordance with paragraph 4.7, there shall be no dielectric breakdown or leakage current flow greater than 5.0 milliamps when voltage is applied.

3.6.4 Insulation Resistance (IR)

Insulation resistance shall be greater than 5,000 megohms when tested in accordance with paragraph 4.8. (See paragraph 3.2.3.)

3.6.5 Contact Capacitance

When tested in accordance with paragraph 4.9, capacitance between adjacent contacts shall not exceed 2.5 picofarads (pF).

3.6.6 Contact Inductance

When tested in accordance with paragraph 4.10, contact inductance shall not exceed 30 nanohenries (nH) per contact.

3.6.7 Contact Impedance

When tested in accordance with paragraph 4.11, contact impedance shall not exceed 105 ohms per contact.

3.6.8 Propagation Delay

When tested in accordance with paragraph 4.12, propagation delay shall not exceed 300 picoseconds (pS) per contact.

3.7 Mechanical Requirements

3.7.1 Interchangeability

When examined in accordance with paragraph 4.13, receptacles of a given style shall be capable of being mated with associated plugs covered by the requirements of this specification. The individual plugs and receptacles having related part numbers from this specification shall be directly and completely interchangeable with each other.

3.7.2 Contact Engagement Force

Insertion force of contacts shall not exceed 4.0 oz. (for approximate size 28 contacts) when tested in accordance with paragraph 4.14.

3.7.3 Contact Separation Force

Removal of contacts shall not be less than 0.5 oz. (for approximate size 28 contacts) when tested in accordance with paragraph 4.15.

3.7.4 Mating/Unmating Force

When tested in accordance with paragraph 4.16, measured force to mate and unmate connectors shall not exceed the following: Mating: $.25 \times$ number of contacts (oz.), unmating: $.04 \times$ number of contacts (oz.).

3.7.5 Oversized Pin Exclusion

(Applies to socket contacts only.) When tested in accordance with paragraph 4.17, socket contacts shall not allow an oversized test pin to engage the contact and shall withstand axial loading of 5 ounces without damage.

3.7.6 Contact Retention

When tested in accordance with paragraph 4.18, the connector housing shall withstand an axial loading applied to contacts without damage. Axial contact displacement shall not exceed 0.015 inches.

3.7.7 Contact Life

When tested in accordance with paragraph 4.19, there shall be no damage or excessive wear that would interfere with operation.

3.7.8 Solderability

When tested in accordance with paragraph 4.20, contacts shall exhibit proper wetting when soldered. The solder coating shall be smooth and continuous without pinholes or voids as shown in IPC/EIA J-STD-002.

3.7.9 Resistance to Soldering Heat

When tested in accordance with paragraph 4.21, connectors shall not exhibit distortion or damage to the insert or contacts from heating.

3.8 Environmental Requirements

3.8.1 Random Vibration, Connector Level

When tested as specified in paragraph 4.22 connectors shall not be damaged by vibration, and there shall not be any circuit interruptions (opens) in excess of 10 nanoseconds. Contacts shall not exhibit evidence of mechanical wear-through (fretting) and debris of the contact finish. There shall be no evidence of axial movement of the test samples relative to each other.

3.8.2 Mechanical Shock

When tested in accordance with paragraph 4.23, connectors shall not exhibit damage or exhibit discontinuity greater than 10 nanoseconds. Following exposure, contacts shall pass low-level contact resistance (LLCR) measurements.

3.8.3 Random Vibration, Chassis Level

When tested as specified in paragraph 4.24, connectors shall not be damaged during testing. There shall not be any interruptions greater than 50 nanoseconds for each of the monitored circuits.

3.8.4 Temperature Cycling

When tested as specified in paragraph 4.25, there shall not be any evidence of physical damage (cracks) caused by temperature cycling. Following temperature cycling, contact resistance shall remain $\leq 20 \text{ m}\Omega$ and insulation resistance shall remain $\geq 5,000 \text{ M}\Omega$. Mating and unmating force shall remain within the limits specified in paragraph 3.7.4.

3.8.5 Humidity

When tested as specified in paragraph 4.26, electrical and mechanical performance of samples shall not be influenced or deteriorated by the effects of high humidity. Following humidity testing, low-level contact resistance and contact resistance shall remain $\leq 20 \text{ m}\Omega$. Insulation resistance shall remain $\geq 5,000 \text{ M}\Omega$.

3.8.6 Mixed Flowing Gas

When tested as specified in paragraph 4.27, there shall not be any corrosion damage on the contacting surfaces that would result in degraded continuity performance. (See application note 6.2.3.) Corrosion on the contact surfaces shall not result in mechanical or electrical malfunction of the connector. LLCR shall remain ≤ 20 m Ω .

3.8.7 Salt Spray

When tested as specified in paragraph 4.28, there shall not be any corrosion damage on the contacting surfaces that would result in degraded continuity performance. Corrosion on the contact surfaces shall not result in mechanical or electrical malfunction of the connector. Low-level contact resistance and contact resistance shall remain ≤ 20 m Ω .

3.9 **Identification**

3.9.1 Part Number

The NASA Goddard Space Flight Center (GSFC) part number shall be as specified in paragraph 1.3.

3.9.2 Date Code

Each connector shall be identified by a date code that shows the year and week of manufacture in accordance with MIL-STD-1285.

3.9.3 Part Marking

Each connector, adapter, or fixture shall be permanently and legibly marked with the NASA GSFC and manufacturer's part number, date code, manufacturer's name or trademark, and CAGE code per MIL-STD-1285. Marking for all MPC keys shall be on the packaging.

4.0 **QUALITY ASSURANCE PROVISIONS**

4.1 **Responsibility for Inspecting**

Unless otherwise specified, the manufacturer is responsible for the performance of all qualification and screening. NASA GSFC reserves the right to re-inspect the connectors and to designate representatives for in-plant surveillance and acceptance functions in conjunction with procurement of connectors to this specification.

4.2 Qualification and Periodic Testing

The connectors supplied to this specification shall be subjected to the qualification requirements of Table I. Periodic (retention of qualification) testing shall consist of Group 1, 2, 3, 4A, and 4B testing, and shall be performed every 3 years. No failures are allowed for qualification or periodic testing. A test summary report must be prepared and submitted to GSFC for approval. Refer to paragraph 6.3.

4.2.1 Sampling

The sampling plan for the test groups listed in Table I shall be as follows:

Group 1, four mated connector pairs designated samples 01 to 04. Samples shall be terminated to test coupon boards.

Group 2, two mated connector pairs, samples 01 and 02 from Group 1.

Group 3, two mated connector pairs, samples 03 and 04 from Group 1.

Group 4A, two mated connector pairs, samples 03 and 04 from Group 3.

Group 4B, two mated connector pairs designated samples 05 and 06. Samples shall have passed the visual examination portion of Group A prior to their selection. Samples shall be prepared for testing with appropriate connectors terminated to the solder tails of contact sample locations (chosen at random) to allow for electrical measurements.

Group 4C, two mated connector pairs, samples 03 and 04 from Group 4A.

Mixed flowing gas group (MFG), two mated connector pairs designated samples 07 and 08. Samples shall be terminated to test coupon boards. Samples shall have passed the visual examination portion of Group A prior to their selection.

Chassis vibration, one chassis equipped with boards per paragraph 4.24. Each free daughterboard shall be populated with two 110 contact style A connectors, two 110 contact style B connectors, and one 95 contact style B connector in a 6U configuration as documented in PICMG 2.0 R3.0. The fixed motherboard shall contain mating connectors configured to accommodate five daughterboards.

4.2.2 Disposition of Qualification Samples

Sample units shall not be delivered with the purchase order and shall be maintained on file for a period of 5 years after completion of qualification.

4.3 Quality Conformance Inspection

The connectors shall be subjected to Group A and B testing inspection per Table II in the order shown.

Table I. Qualification Requirements

Test No.	Test Description	Test References		
		Requirement Paragraph	Test Paragraph	Test Specification
Pre-Production Examinations				
	Materials Analysis	3.5	4.29	
Group 1				
1	Visual and Mechanical Examination	3.3	4.4	EEE-INST-002, Sect. C2, Tables 4A and 4B and MIL-DTL-55302
2	Interchangeability	3.7.1	4.13	MIL-DTL-55302
3	Oversized Pin Exclusion	3.7.5	4.17	MIL-DTL-55302
4	Engagement Force	3.7.2	4.14	EIA-364-37
5	Separation Force	3.7.3	4.15	EIA-364-37
6	Contact Retention	3.7.6	4.18	EIA-364-29
7	Contact Resistance	3.6.1	4.5	EIA-364-06
8	Low-Level Contact Resistance	3.6.2	4.6	MIL-DTL-55302
9	Dielectric Withstanding Voltage (DWV, Sea Level)	3.6.3	4.7	EIA-364-20
10	Insulation Resistance	3.6.4	4.8	EIA-364-21
11	Mating/Unmating Force	3.7.4	4.16	EIA-364-13
Group 2				
1	Dielectric Withstanding Voltage (DWV, Altitude)	3.6.3	4.7	EIA-364-20
2	Contact Life	3.7.7	4.19	EIA-364-09
3	Random Vibration, Connector Level	3.8.1	4.22	EIA-364-28
4	Mechanical Shock	3.8.2	4.23	EIA-364-27
5	Salt Spray	3.8.7	4.28	EIA-364-26
Group 3				
1	Temperature Cycling	3.8.4	4.25	EIA-364-32
2	Humidity	3.8.5	4.26	EIA-364-31
Group 4A				
1	Solderability	3.7.8	4.20	EIA-364-52
2	Resistance to Soldering Heat	3.7.9	4.21	EIA-364-56

Table I (Cont'd.). Qualification Requirements

Test No.	Test Description	Test References		
		Requirement Paragraph	Test Paragraph	Test Specification
Group 4B Electrical				
1	Contact Capacitance	3.6.5	4.9	EIA-364-30
2	Contact Inductance	3.6.6	4.10	EIA-364-33
3	Contact Impedance	3.6.7	4.11	EIA-364-108
4	Propagation Delay	3.6.8	4.12	EIA-364-103
Group 4C				
1	Visual and Mechanical Examination	3.3	4.4	
2	Interchangeability	3.7.1	4.13	MIL-DTL-55302
3	Mating/Unmating Force	3.7.4	4.16	EIA-364-13
Mixed Flowing Gas				
1	Low-Level Signal Contact Resistance	3.6.2	4.6	EIA-364-23
2	Mixed Flowing Gas	3.8.6	4.27	EIA-364-65
Chassis Vibration				
1	Random Vibration, Chassis Level	3.8.3	4.24	EIA-364-28

Table II. Quality Conformance Requirements

Test No.	Test Description	Reference Documents		
		Requirement Paragraph	Test Paragraph	Test Specification
Group A Screening 100% Tests				
1	Visual Examination (Exterior of all completed connectors and 100% of Hypertac™ sockets)	3.3	4.4	EEE-INST-002, Sect. C2, Tables 4A and 4B, and MIL-DTL-55302
Group B Sample Tests (Two Samples from Each Lot Except as Noted) 1/, 2/				
2	Mechanical/Dimensional Examination (Four Samples)	3.3	4.4	Same as Visual
3	Dielectric Withstanding Voltage (DWV, Sea Level)	3.6.3	4.7	EIA-364-20
4	Insulation Resistance	3.6.4	4.8	EIA-364-21
5	Temperature Cycling	3.8.4	4.25	EIA-364-32
6	Resistance to Soldering Heat	3.7.9	4.21	EIA-364-56
7	Mating/Unmating Force	3.7.4	4.16	EIA-364-13
8	Final Visual		4.4	Same as Step 1

Table II Notes:

1/ Tests shall be performed in the order shown.

2/ Group B sample units shall not be delivered with the purchase order.

4.4 Visual and Mechanical Examination

Perform visual inspection of connectors and Hypertac™ socket contacts for workmanship flaws using a minimum of 3X magnification and adequate lighting. Perform dimensional measurements on samples. Measurements shall comply with specification requirements. For criteria, use GSFC EEE-INST-002, Section C2, Table 4A for PC style connectors and Table 4B for PC contacts. A partial list is as follows:

1. Body: Cracks, voids.
2. Leads: Bent, cracked/broken leads; burrs; broken socket contact wires.
3. Plating: Adhesion/peeling, porosity/exposed bare metal, corrosion.

4.5 Contact Resistance

Measurements shall be performed and recorded in accordance with EIA-364, test procedure 06. Set source voltage to 1.0 VDC. Applied current shall be 1.0 A DC. Testing shall be performed on seven contact positions per mated connector pair.

4.6 Low-Level Signal Contact Resistance

Measurements shall be performed and recorded in accordance with EIA-364, test procedure 23, method B. Set source voltage to 20 mVDC. Applied current shall be 100 milliamps. Testing shall be performed on seven contact positions per mated connector pair (same as in paragraph 4.5).

4.7 Dielectric Withstanding Voltage (DWV)

Perform in accordance with MIL-DTL-55302 and EIA-364-20. Hold time shall be 60 seconds. Contacts shall be alternately wired like the fields on a chess board, so that every other contact is daisy-chained to the same potential. All contacts in row F shall be wired together to ground. Adjust chamber pressure and apply voltage as follows: For sea level, apply 750 VRMS in accordance with EIA-364-21, test condition I. For 70,000 ft. altitude, apply 300 VRMS in accordance with EIA-364-21, test condition IV.

4.8 Insulation Resistance

When tested in accordance with MIL-DTL-55302 and EIA-364-21, insulation resistance readings shall be within the limits specified in paragraph 3.6.4. Contacts shall be wired (same as in paragraph 4.7). Applied voltage shall be 500 VDC, and electrification time shall be 60 seconds.

4.9 Contact-to-Contact Capacitance

Contacts shall be tested in accordance with EIA-364-30 using a 10 MHz frequency. Five observations per connector shall be taken.

4.10 Contact Inductance

Contacts shall be tested in accordance with EIA-364-33. Contact points shall be terminated with RF connectors. Applied frequency shall be 10 MHz. Five contacts per connector shall be tested.

4.11 Contact Impedance

Contacts shall be tested in accordance with EIA-364-108 using the same test setup as in paragraph 4.10. Set equipment rise time to 35 picoseconds.

4.12 Propagation Delay

Contacts shall be tested in accordance with EIA-364-103 using the same test setup as in paragraph 4.10.

4.13 Interchangeability

Connectors shall be subjected to dimensional verification in accordance with MIL-DTL-55302, paragraph 4.5.1. All materials shall be certified to be in accordance with the requirements of this specification.

4.14 Contact Engagement Force

Socket contacts shall be measured in accordance with MIL-DTL-55302, paragraph 4.5.3 and EIA-364-37. A force gage and test stand shall be used. Engagement pin gage diameter shall be $0.016 + 0.00 - 0.002$ inches. Insertion depth shall be 0.112 ± 0.005 inches. Ten readings shall be taken.

4.15 Contact Separation Force

Socket contacts shall be measured in accordance with MIL-DTL-55302, paragraph 4.5.3, and EIA-364-37. Separation pin gage diameter shall be $0.015 + 0.002 - 0.00$ inches. Ten readings shall be taken using the setup and insertion depth from paragraph 4.14.

4.16 Mating/Unmating Force

Connectors shall be tested in accordance with EIA-364-13, method A. Connectors shall be terminated, mounted to a fixture, and tested with a force gage. Connectors shall be gradually mated using a rate of 1.0 inch per minute.

4.17 Oversized Pin Exclusion

Contacts shall be tested in accordance with MIL-DTL-55302, paragraph 4.5.2, using a test pin having a diameter of 0.0207 inches inserted with a force of 5 ounces. Four contacts shall be tested.

4.18 Contact Retention

Connector contacts shall be tested in accordance with EIA-364-29. The load shall be applied longitudinally to the contact in an unmating direction and shall be 2.25 pounds for a 5-second duration. Contact displacement shall be measured and shall not exceed the value in paragraph 3.7.6. Seven contact positions shall be measured.

4.19 Contact Life

Contacts shall be tested in accordance with EIA-364-09. Align connector test samples. 500 mate and unmate cycles shall be performed using a special holding fixture, and connectors shall be automatically cycled at a rate of less than 600 mating cycles per hour. Following mating cycles, the contacts shall be examined for evidence of mechanical damage.

4.20 Solderability

Connector contacts shall be tested in accordance with EIA-364-52. The following test details shall apply:

1. Steam aging is required.
2. Type ROM0 flux (formerly RMA flux) shall be used.
3. Flux immersion shall be from 5 to 10 seconds.
4. Solder shall be applied at a temperature of 260 °C +/- 5 °C, with a dwell time of 4 to 5 seconds.
5. Isopropyl alcohol shall be used as the cleaning agent. Test specimens shall be visually inspected using 10X magnification.

4.21 Resistance to Soldering Heat

Connectors shall be tested in accordance with EIA-364-56, test procedure 3 (solder dip) using Sn63Pb37 solder and type ROM0 flux (formerly RMA flux). Solder shall be applied at a temperature of 350 °C +/- 5 °C, and dwell time shall be 4 to 5 seconds.

4.22 Random Vibration, Connector Level

Testing shall be performed in accordance with EIA-364-28, test condition III (profile: 10 – 2 KHz, 15 G, 20-minute cycle), with the following details and exceptions:

1. Connectors shall be mated, and seven contact positions shall be wired for monitoring. Provisions shall be made to assure that the connectors do not become de-mated during testing.
2. Contacts shall be monitored for circuit interruptions in accordance with EIA-364-87 test method 1 (time domain reflectometry [TDR] technique and an event detector).
3. Test duration shall be 4 hours per axis, 12 hours total.
4. Following testing, low-level contact resistance shall be performed in accordance with EIA-264-23, with an applied current of 100 milliamps, maximum.

4.23 Mechanical Shock

(Specified pulse) testing shall be performed in accordance with MIL-DTL-55302, paragraph 4.5.14, and EIA-364-27. The following details shall apply:

1. 100 G peak value, 6 millisecond duration, sawtooth wave form.
2. Perform three shocks in each direction of three mutually perpendicular axes, total of 18 shocks.
3. Use the same wiring setup for seven sets of mated contacts as used in 4.22 random vibration.
4. Circuits shall be monitored for nanosecond event detection using TDR in accordance with EIA-364-87.
5. Following exposure, contacts shall be measured for low-level contact resistance (see paragraph 4.6).

4.24 Random Vibration, Chassis Level

Testing shall be performed in accordance with EIA-364-28, test condition III (profile: high frequency, 20 to 2 KHz, 14.1 Gs RMS, 147.1 m/s²), with the following details and exceptions:

1. Connectors shall be terminated to printed circuit boards (6U board configuration in accordance with PICMGTM 2.0 R3.0, one 6U fixed motherboard, and five 6U free daughterboards). PCBs shall be mounted in a covered chassis, with connectors mated and boards securely fastened in place.
2. Boards shall use simulated electrical, electronic, and electromechanical (EEE) component masses.
3. All contacts of mated connectors shall be wired in order to create multiple daisy chain circuits for interrupt monitoring.
4. Low nanosecond event detection shall be performed for each circuit in accordance with EIA-364-87, test method 1 (TDR technique with event detector).

4.25 Temperature Cycling

Testing shall be performed in accordance with EIA-364-32, test condition III (-65 °C to +125 °C) for five cycles. Connectors shall be mated and mounted to test boards. Dwell time shall be 30 minutes at each exposure. Following exposure, contact resistance shall be measured and recorded (see paragraph 4.5). Insulation resistance shall be measured and recorded (see paragraph 4.8). Mating and unmating force shall be measured (see paragraph 4.16).

4.26 Humidity

Testing shall be performed in accordance with EIA-364-31, with the following details:

1. Connectors shall be preconditioned at 50 °C for 24 hours.

2. Test duration, condition C (500 hours).
3. Applied voltage shall be 100 VDC.
4. Relative humidity shall be 90% to 95%.
5. Temperature profile shall be 25 °C to 65 °C.
6. Connectors shall be mated and mounted. Following exposure, low-level contact resistance shall be measured and recorded (see paragraph 4.6). Contact resistance shall be measured and recorded (see paragraph 4.5). Insulation resistance shall be measured and recorded (see paragraph 4.8).

4.27 Mixed Flowing Gas

Testing shall be performed in accordance with EIA-364-65, using the chemicals found in (Battelle) environmental class IIIa. Following exposure, low-level contact resistance shall be measured and recorded (see paragraph 4.5).

4.28 Salt Spray

Testing shall be performed in accordance with EIA-364-26. Following exposure, low-level contact resistance shall be measured and recorded (see paragraph 4.6). Contact resistance shall be measured and recorded (see paragraph 4.5).

4.29 Materials Analysis

Materials analysis verification testing using appropriate test methods shall be performed on raw material stock to verify that material composition and properties conform to the requirements of the specifications referenced in paragraph 3.5.

5.0 PREPARATION FOR DELIVERY

5.1 Packaging

Each connector, adapter, or fixture shall be individually packaged and sealed in a dust-free, moisture-proof container. The overall package shall be sufficient to protect connectors from damage when shipped by any common carrier. Each connector and adapter shall be packaged in a clear plastic bag or vial so that the connector and marking are visible.

5.2 Marking

Each shipping package shall be marked permanently and legibly with the NASA GSFC and manufacturer's part number and manufacturer's name or trademark.

5.3 Test Data Package

A test data package that provides Group A screening test results and certificate of conformance shall be supplied along with the connectors.

Table III. Connector Part Numbers, Accessories, and Description

	Part Number <u>1/</u>	Description	Figure <u>2/</u>
110 Contact Connectors	311P822-FC-110-AG-D(X)	Female motherboard connector, 110 socket contacts, style A, gold flash solder tail, length per 1.3.1	2
	311P822-FC-110-AS-D(X)	Female motherboard connector, 110 socket contacts, style A, solder coated tail, length per 1.3.1	
	311P822-MC-110-AG-D(X)	Male daughterboard connector, right angle, 110 pin contacts, style A, gold flash solder tail, length per 1.3.1	3
	311P822-MC-110-AS-D(X)	Male daughterboard connector, right angle, 110 pin contacts, style A, solder coated tail, length per 1.3.1	
	311P822-FC-110-BG-D(X)	Female motherboard connector, 110 socket contacts, style B, gold flash solder tail, length per 1.3.1	4
	311P822-FC-110-BS-D(X)	Female motherboard connector, 110 socket contacts, style B, solder coated tail, length per 1.3.1	
	311P822-MC-110-BG-D(X)	Male daughterboard connector, right angle, 110 pin contacts, style B, gold flash solder tail, length per 1.3.1	5
	311P822-MC-110-BS-D(X)	Male daughterboard connector, right angle, 110 pin contacts, style B, solder coated tail, length per 1.3.1	
95 Contact Connectors	311P822-FC-095-BG-D(X)	Female motherboard connector, 95 socket contacts, style B, gold flash solder tail, length per 1.3.1	6
	311P822-FC-095-BS-D(X)	Female motherboard connector, 95 socket contacts, style B, solder coated tail, length per 1.3.1	
	311P822-MC-095-BG-D(X)	Male daughterboard connector, right angle, 95 pin contacts, style B, gold flash solder tail, length per 1.3.1	7
	311P822-MC-095-BS-D(X)	Male daughterboard connector, right angle, 95 pin contacts, style B, solder coated tail, length per 1.3.1	

Table III (Continued). Connector Part Numbers, Accessories, and Description

	Part Number	Description	Figure
110 Contact Adapter Connectors	311P822-FA-110-A	Female adapter, style A, 110 contacts, mates 311P822 female motherboard connector to commercial cPCI™ daughterboard connector	8
	311P822-MA-110-A	Male adapter, style A, 110 contacts, mates 311P822 male daughterboard connector to commercial cPCI™ motherboard connector	9
	311P822-FFA-110-A	Female-to-female adapter, style A, 110 contacts, mates two 311P822 male daughterboard connectors together	10
	311P822-FA-110-B	Female adapter, 110 contacts, style B, mates 311P822 female motherboard connector to commercial cPCI™ daughterboard connector	11
	311P822-MA-110-B	Male adapter, 110 contacts, style B, mates 311P822 male daughterboard connector to commercial cPCI™ motherboard connector	12
	311P822-FFA-110-B	Female-to-female adapter, style B, 110 contacts, mates two 311P822 male daughterboard connectors together	13
95 Contact Adapter Connectors	311P822-FA-095-B	Female adapter, 95 contacts, style B, mates 311P822 female motherboard connector to commercial cPCI™ daughterboard connector	14
	311P822-MA-095-B	Male adapter, 95 contacts, style B, mates 311P822 male daughterboard connector to commercial cPCI™ motherboard connector	15
	311P822-FFA-095-B	Female-to-female adapter, style B, mates two 95 contact 311P822 male daughterboard connectors together	16
Solder Holding Fixture	311P822-BPF	6U backplane fixture, for soldering 6U motherboard connectors	17
	311P822-DCF	6U daughter card fixture, for soldering 6U daughterboard connectors	18
MPC Key	311P822-MK-XX <u>3/</u>	MPC key, male	19
	311P822-FK-XX <u>4/</u>	MPC key, female	20

Table III Notes:

- 1/ Replace (X) with length designator as specified in paragraph 1.3.3.
- 2/ Identification for contact position 1 appears on the motherboard female (fixed) connector only. All other contact identification shown in the figure is for reference only. See 6.1.2.5.4.
- 3/ Replace (X) with key code designator as specified in Figure 19.
- 4/ Replace (X) with key code designator as specified in Figure 20.

6.0 NOTES

6.1 Application Notes

6.1.1 Intended Use

Connectors in this specification are intended to be a ruggedized high-reliability alternative to industry standard press-fit compliant pin cPCI™ connectors, and are specifically designed to withstand harsh environments that include shock, vibration, and temperature extremes. **The contacts are physically different between industry standard cPCI™ connectors and the 311P822 style cPCI™ connector.** Users need to be aware that when using 311P822 connectors to replace cPCI™ connectors in an existing design, **both connector halves must be changed, and the board layout should be checked for mating alignment of the boards.**

6.1.1.1 Motherboard (AKA Fixed/Backplane) Connectors. Fixed motherboard connectors are mounted on the unit backplane and utilize straight Hypertac™ (wirebasket) socket contacts.

6.1.1.2 Daughterboard (AKA Free) Connectors. Daughterboard connectors consist of pin contacts with right angle terminations. They are mounted on the edge of the daughterboards, and when mated with the motherboard (backplane/fixed) connectors will result in boards being installed perpendicular to the motherboard/backplane. The daughterboard connectors consist of molded pin contact module “chicklets” that are assembled together in parallel to make the connector.

6.1.2 Differences Between cPCI™ and 311P822 Connectors

6.1.2.1 Connector Compatibility. **The 311P822 cPCI™ connector will not mate with industry standard cPCI™ connectors.** The S-311-P-822 connectors utilize machined socket contacts (Hypertac™). Industry standard cPCI™ connectors utilize stamped fork contacts.

Connector adapters are available that will mate S-311-P-822 connectors with industry standard cPCI™ connectors for use with test equipment; see paragraph 6.1.6.

6.1.2.2 Contact Gender. The contacts used in S-311-P-822 connectors are “gender reversed” from industry standard cPCI™ connectors. That is, where the 311P822 uses Hypertac™ socket contacts in the motherboard (fixed/backplane) connector and pin contacts in the daughterboard (free) connector, industry standard cPCI™ connectors use blade contacts in the motherboard (fixed/backplane) connector and fork contacts in the daughterboard (free) connectors. This was performed in order to obtain a more conventional chassis design typical of MIL-DTL-55302 connectors, where more robust socket contacts are used within the motherboard (fixed/backplane) connector inserts, and pin contacts that are more easily bent from handling are protected within the daughterboard (free) connector inserts.

6.1.2.3 Board Solder Terminations. The contacts used in 311P822 connectors are specifically designed for solder termination into plated through-holes for high reliability, versus industry cPCI™ connectors that utilize a pressed interference fit compliant pin termination with board plated through-holes. **Dimensioning and tolerancing of plated through-holes is critical to assure proper through-hole solder fill.** To minimize the potential for insert deformation from solder heat, high-temperature molding material is used for the 311P822 connector inserts.

6.1.2.4 Contact Engagement Force. Low insertion force Hypertac™ socket contacts are used for 311P822 connectors.

6.1.2.5 cPCI™ Basics. There are two industry specifications that are used to establish cPCI™ connector designs, Compact PCI Specification PICMG™ 2.0 R3.0 and IEC61076-4. The PICMG™ specification uses two “standard” processor board configurations with “standard” architecture contact assignments. Users may utilize these standard architectures or design their own processor architecture.

6.1.2.5.1 *Board Configurations.* Two board configurations are adopted by PICMG™ 2.0 based on the eurocard defined in IEC 60297-3-101. The “3U” configuration (100 mm x 160 mm) utilizes two 2 mm connectors. The “6U” configuration (233.35 mm x 160 mm) utilizes five 2 mm connectors. The PICMG™ 2.0 document provides layouts for two-sided 3U and 6U backplane designs having front plug-in boards and rear plug-in boards. For typical space flight applications, only the front plug-in backplanes and boards are used. The 3U board layout is shown in PICMG™ 2.0 R3.0, Figure 6. The 6U board layout is shown in Figure 7. **The optional mounting holes for tooling must be provided for solder fixture attachment.**

6.1.2.5.2 *Connector Configurations.* IEC61076-4-101 establishes “standard” 2 mm connector configurations that are used to terminate PICMG™ processor board architectures, where 2 mm represents the centering between any two adjacent contacts. Various insert styles are offered, but of these only two of the connector styles are described in this document: style A connectors that have an alignment feature and multi-purpose center where keying can be applied, and style B connectors that are plain and do not have the MPC or alignment features. (For style A keyed connectors, contact positions 12 through 14 are omitted.)

Both connector styles have motherboard connectors and daughterboard connector counterparts. Daughterboards are mounted to motherboard backplanes through the use of card slots that must be secured together (see paragraph 6.1.2.5.5).

6.1.2.5.3 *Connector Row Identification.* The cPCI™ connectors described in this specification contain six rows designated A through F, where row F is a row of grounding pins associated with a shield that covers the top of the daughterboard connector.

In IEC61076-4-101, there is an optional second shield offered so that both sides of the daughterboard connector can be shielded. This shield terminates to grounding row Z in the industry cPCI™ motherboard connector. If the shield is not used, row Z of the connector is not used but is still terminated. This optional grounding row Z is not an option in this NASA Goddard specification.

6.1.2.5.4 *311P822 Contact Numbering.* **The NASA GSFC S-311-P-822 specification has adopted the contact numbering scheme for the connector implementation that is documented in Compact PCI PICMG™ specification** Figure 22 and Appendix B. This numbering is opposite of the method used in IEC61076-4-101. For Figures 2 through 7 of GSFC S-311-P-822, contact numbering is shown using the IEC61076-4-101, and this marking does not actually appear on the connector. **It is up to users to specify which identification method is applied to their design and to number contact positions accordingly.**

The contact identification method adopted by PICMG™ 2.0 is for viewing the backplane vertically from the front. The connector positions are numbered from the bottom connector (designated P1) to the top connector (P5), and the contacts are numbered vertically from the bottom of each connector to the top. The contact rows are lettered A through F from left to right. Pin 1 becomes the right-most contact on the bottom of connectors P1 through P5. Each motherboard connector has a pin 1 identifier. There are no other contact numbers marked on these connectors.

6.1.2.5.5 *Securing Mated Connectors.* The connectors do not provide for hardware to secure mated connectors together. Securing the mated connectors together for space flight is accomplished through card slot wedge locks. Locking card ejectors (applied to the boards upon installation) are commonly used for ground support but are not recommended for flight.

6.1.2.6 *Motherboard Connector Board Layout and Substitution for cPCI™.* 311P822 connectors use the same 2 mm contact pitch grid dimensions that industry press-fit cPCI™ connectors use as documented in IEC 61076-4-101. However, if a motherboard footprint was laid out for industry cPCI™ connectors, the layout would require terminations for row Z. Since row Z is not offered by specification S-311-P-822, if 311P822 fixed motherboard connectors are substituted for an existing cPCI™ board design, these holes would not be used, leaving empty holes in the board unless the holes are filled or the board footprint is changed.

When substituting 311P822 connectors for cPCI™ connectors, users must perform the following:

1. **Re-check the clearance between any tall components on the outer boards and the card cage.** Since row Z is not used, the fixed motherboard connector insert grid is offset by half the centering between row Z and row A, or 1 mm (0.0254 inches) to re-center the grid within the insert. In examining the motherboard connector from the side, with the rear solder tails to the right and the socket contact engagement area to the left, all rows would be shifted up by 1 mm. Consequently, all mating free boards would also be shifted by 1 mm within the chassis.

2. **Re-evaluate if the board's termination hole sizes are appropriate for these connectors.** Typical board plated through-holes for industrial cPCI™ connectors are $0.6 \pm .05$ mm (~0.026"). Refer to the appropriate connector figures of this specification for hole sizes to be used with these connectors.

When wedge locks are used in the PCB cage design, the 311P822 connector can in many cases be used in place of industry cPCI™ connectors without chassis design modification of the connector panel layout, as the wedge locks should take up the difference, but packaging designers must evaluate their own designs in order to ensure alignment and clearance between boards and that their components won't be a problem.

The connectors in this specification do not provide for optional "hot-swap" capability. All board insertions and removals must be performed unpowered.

6.1.3 Mating and Unmating

6.1.3.1 Fixtures. The use of fixtures to mate and demate boards is recommended in order to prevent "rocking" the daughterboard (free) connectors from side to side during mating and unmating that can cause bending of the perimeter contacts. Fixtures can help distribute the mating force along the complete connector contact population rather than concentrating force on the outermost contacts at each end of the connector row.

6.1.3.2 Mating Alignment (First Contact Point). **It is important during initial mating to gently wiggle the daughterboards back and forth. There will be a slight but noticeable settling of the boards into place when the daughterboard pin contacts reach the first contact point with the mating motherboard socket contacts and self align.** This must be achieved prior to applying mating pressure. Failure to have contacts properly aligned may result in motherboard socket contact scraping of the daughterboard inserts and introduction of debris.

6.1.4 Soldering Fixtures

The use of special fixtures to hold connectors in proper alignment and height through board soldering is required. Holding fixtures are offered by Hypertronics that are made of NEMA grade G10 epoxy-impregnated fiberglass laminate. Refer to Table III for ordering information and to Figures 17 and 18 for configuration. **The optional mounting holes for tooling must be used in the board design for attachment of these fixtures.**

6.1.5 Cleaning

Following solder installation, proper cleaning practices must be observed by users in order to prevent induced corrosion of the contacts. Mild solder fluxes are recommended followed by appropriate cleaning.

6.1.6 Connector Adapters

Adapters to mate 311P822 connectors to industry cPCI™ connectors are available that can be used to interface between these connectors and existing test equipment that may have industry cPCI™ connectors. The adapters are not intended to adapt industry cPCI™ product for use in space flight applications.

6.1.7 Trademarks

cPCI™ and PICMG™ are registered trademarks of the PCI Industrial Computer Manufacturers Group. Hypertac™ is a registered trademark of Hypertronics Corporation.

6.2 Test Method Notes

6.2.1 Low Nanosecond Event Detection

Low nanosecond event detection is performed through the use of time domain reflectometry (TDR). In TDR, a voltage signal pulse is applied to the test connector with selected contacts daisy-chained together. Prior to testing, the circuit is characterized through the use of TDR, where a voltage signal pulse is sent through the circuit to determine its characteristic impedance variations along the circuit. When TDR testing is performed during environmental testing such as vibration, if the voltage signal pulse encounters a short-duration resistance increase or open at the connector contacts, a voltage reflection occurs and is detected by the test equipment. This reflection would appear on an oscilloscope as an anomaly when compared to the original signature.

6.2.2 Event Detection

An event detection detector is used to record when an event (interruption) occurs. An event is defined by a change in the resistance of the contact daisy chain circuit for the connector under test that exceeds a preset resistance threshold and duration (time domain) as recorded by an event detector.

6.2.3 Mixed Flowing Gas

Mixed flowing gas testing is performed in order to accelerate the effects of corrosive gases that are found in severe environments. It is an industrial test that is not currently required by any military specification, and it is intended to evaluate the gas-tight integrity of the contact surfaces; that is, the ability of contacting surfaces to prevent the harsh environment from penetrating between mated contact surfaces and forming oxides and films that would increase contact resistance and degrade electrical performance.

6.3 Data Address

When supplemental data, reports, or information requests are to be transmitted to GSFC, the following address shall be used, unless otherwise specified.

Goddard Space Flight Center
Parts, Packaging, and Assembly Technologies Office, Code 562
8800 Greenbelt Road
Greenbelt, Maryland 20771
ATTN: QPLD Administrator

6.4 Ordering Data

Acquisition documents should specify the following:

1. Number, title, and date of this specification.
2. GSFC part number.
3. Quantity.
4. Special screening and packaging provisions (if necessary).

6.5 Qualification Provisions

With respect to products requiring qualification, awards will be made only for products that have been approved by GSFC before the time set for opening of bids. The attention of the supplier is called to this requirement; manufacturers should arrange to have qualification test made on products that they propose to offer to GSFC to become eligible for awards, contracts, or orders for products covered by this specification. Information pertaining to qualification of products may be obtained from the activity whose address is listed in paragraph 6.3.

6.6 Source of Supply

Refer to Table IV and the GSFC Qualified Products List Directory (QPLD) for approved source(s) and part numbers.

6.7 Configuration Control

The source of supply shall not make any changes to these connectors without the written approval of NASA Goddard Space Flight Center, QPLD Administrator.

6.8 Notice

When GSFC drawings, specifications, or other data are used for any purpose other than in connection with a definitely related GSFC procurement operation, the United States Government thereby incurs no responsibility nor any obligation whatsoever; the fact that GSFC might have formulated, furnished, or in any way supplied the said drawings, specifications, or other data is not to be regarded by implication or otherwise in any manner licensing the holder or any person or corporation, or conveying any right or permission to manufacture, use, or sell any patented invention that may in any way be related thereto.

Custodian: QPLD Administrator
Parts, Packaging, and Assembly Technologies Office, Code 562
Goddard Space Flight Center
Greenbelt, Maryland 20771

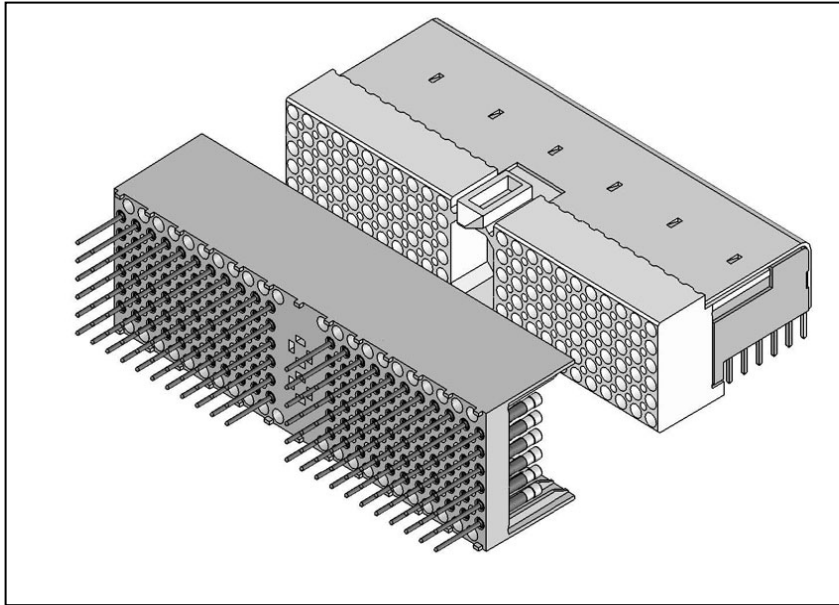

Isometric View of Pair

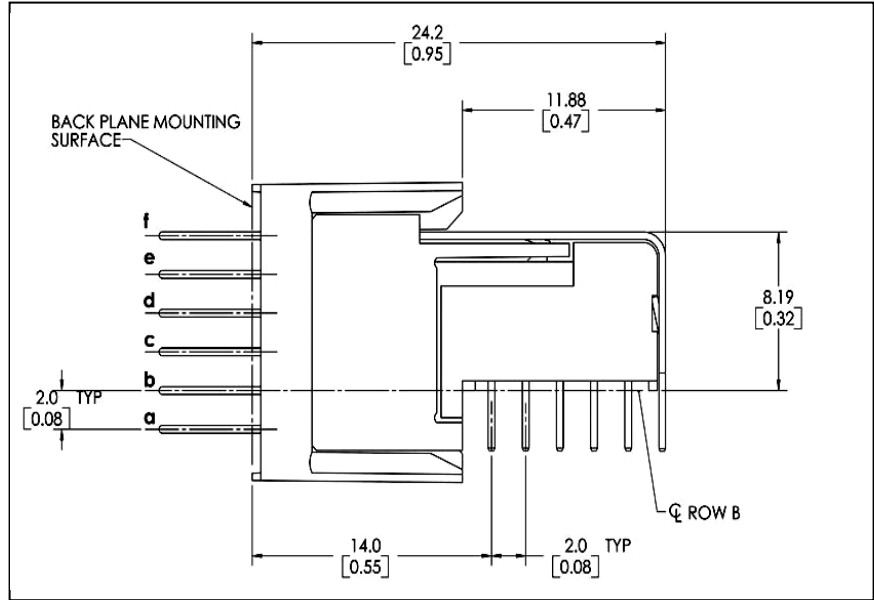

Cross Section of Mated Pair

Figure 1. Typical 2-mm Pair

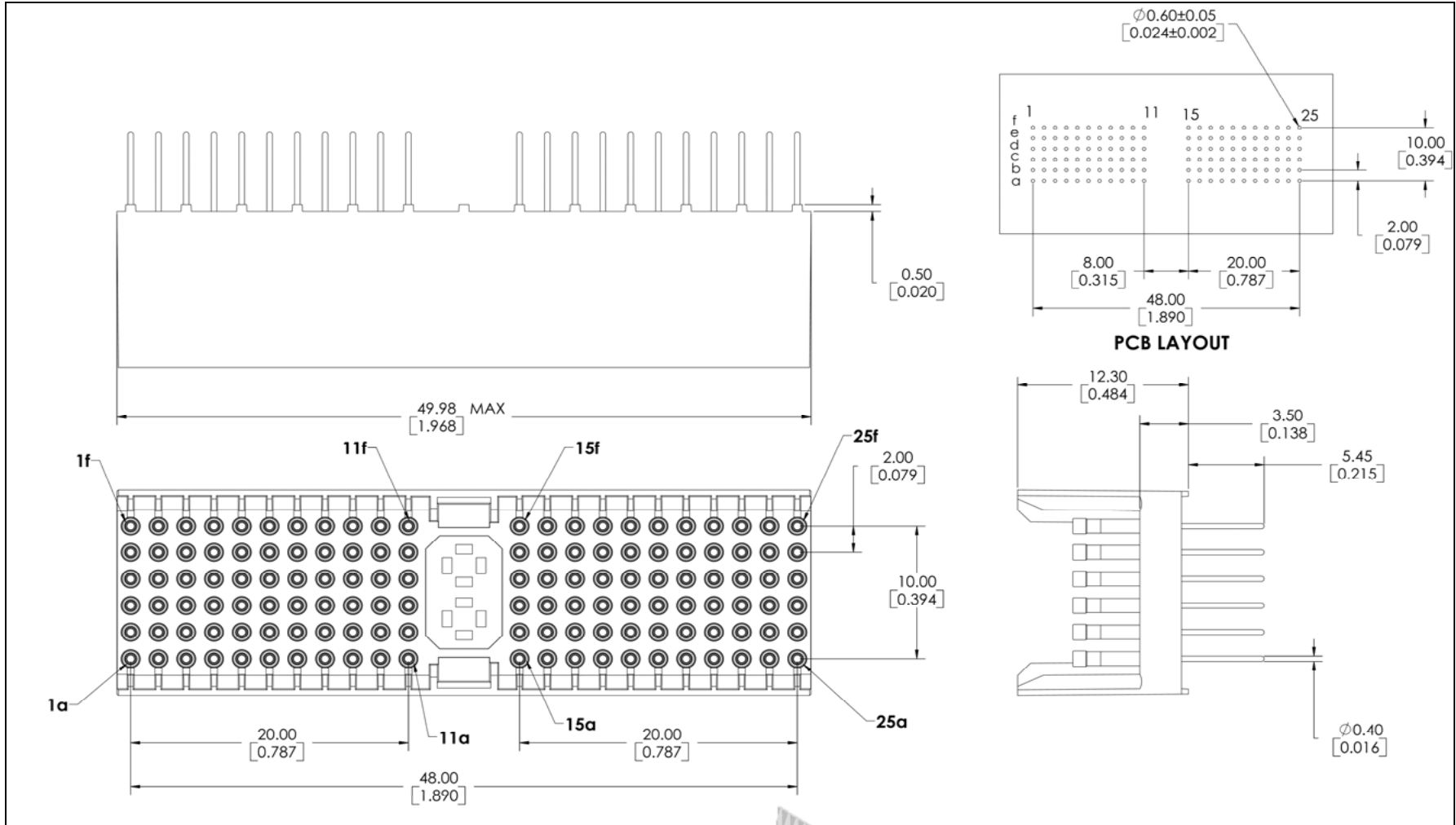

Figure 2. Female Motherboard Backplane Connector, 311P822-FC-110-A(X)-D(X)
110 Socket Contacts, Style A (with MPC)

(Note: Actual solder tail length shall be as specified in 1.3.3, and is referenced from connector standoff.)

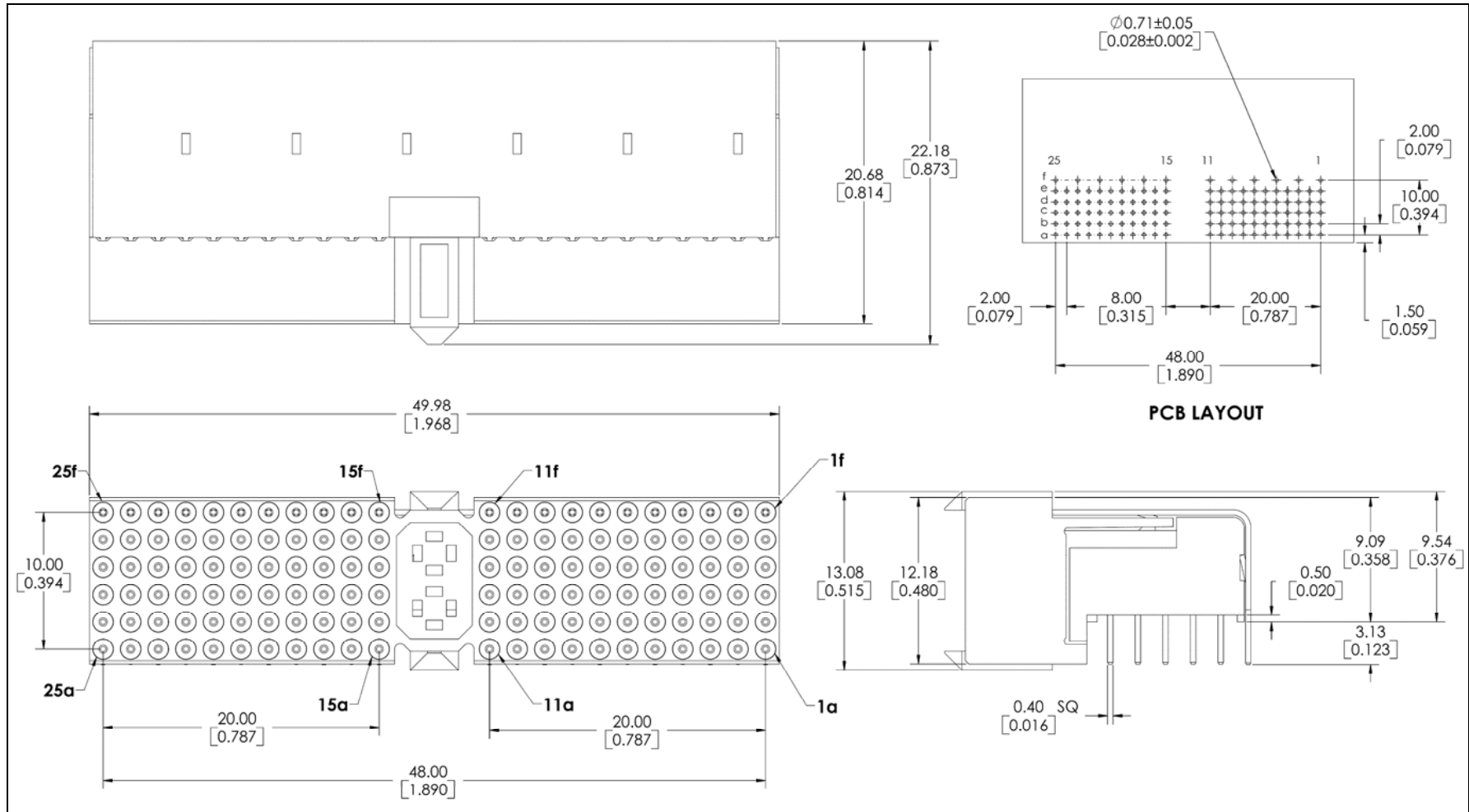

Figure 3. Male Daughterboard Connector, 311P822-MC-110-A(X)-D(X)
Right Angle, 110 Pin Contacts, Style A (with MPC)

(Note: Actual solder tail length shall be as specified in 1.3.3, and is referenced from connector standoff.)

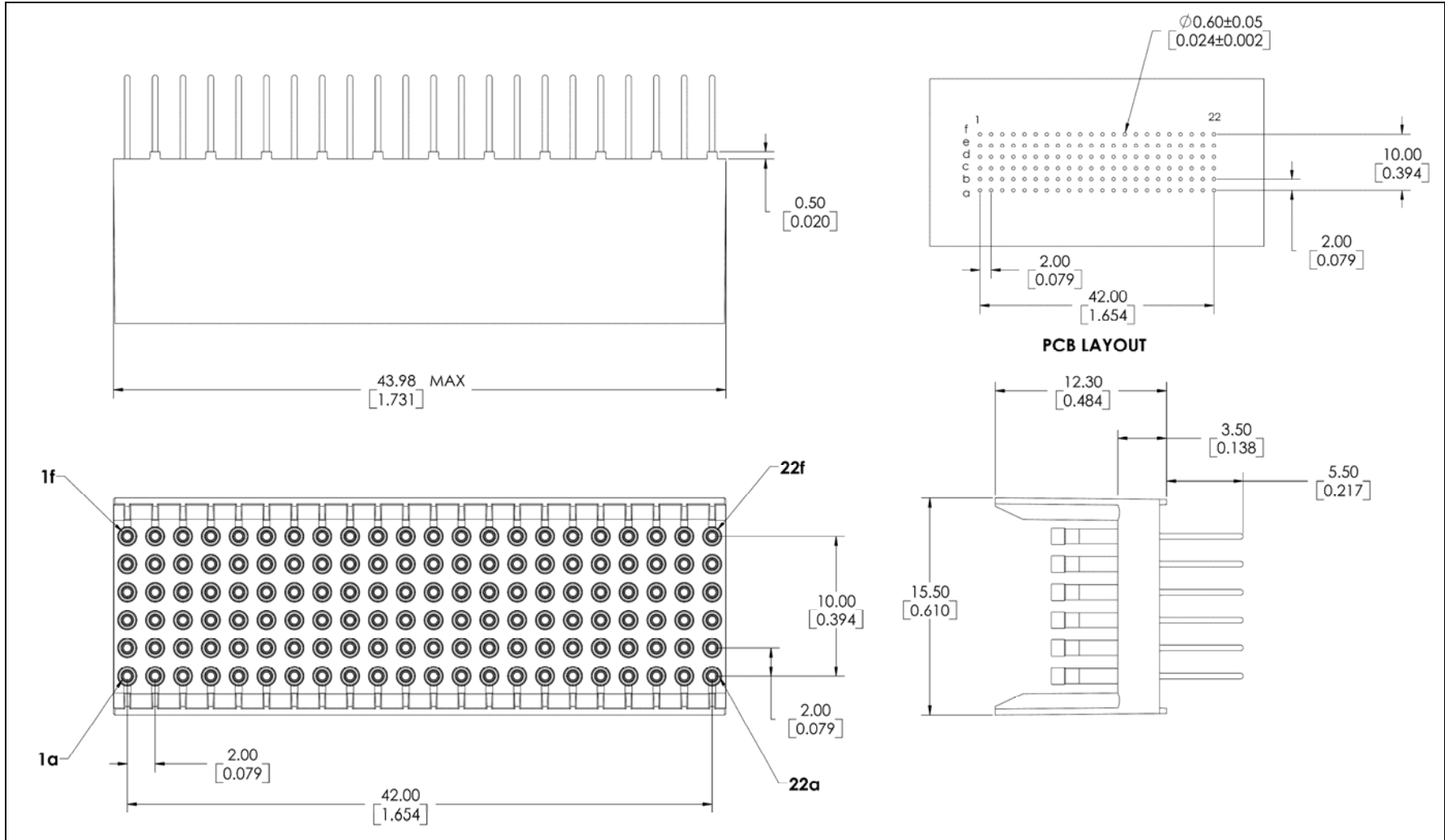

Figure 4. Female Motherboard Backplane Connector, 311P822-FC-110-B(X)-D(X)
110 Socket Contacts, Style B

- (Notes: 1. Actual solder tail length shall be as specified in 1.3.3, and is referenced from connector standoff.
2. Solder tail dimension is 0.40 SQ [0.016 inches].)

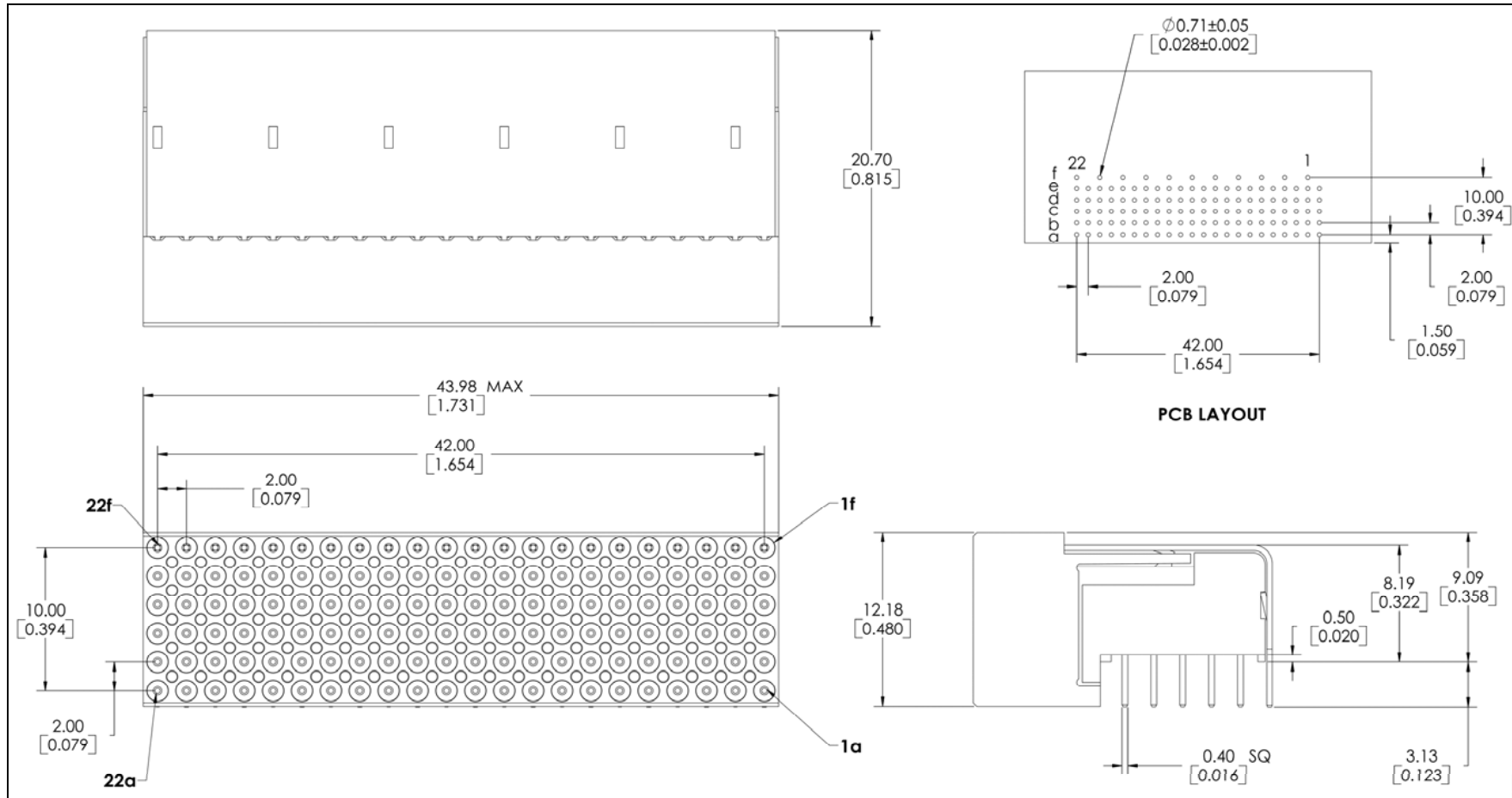

Figure 5. Male Daughterboard Connector, 311P822-MC-110-B(X)-D(X)
Right Angle, 110 Pin Contacts, Style B

(Note: Actual solder tail length shall be as specified in 1.3.3, and is referenced from connector standoff.)

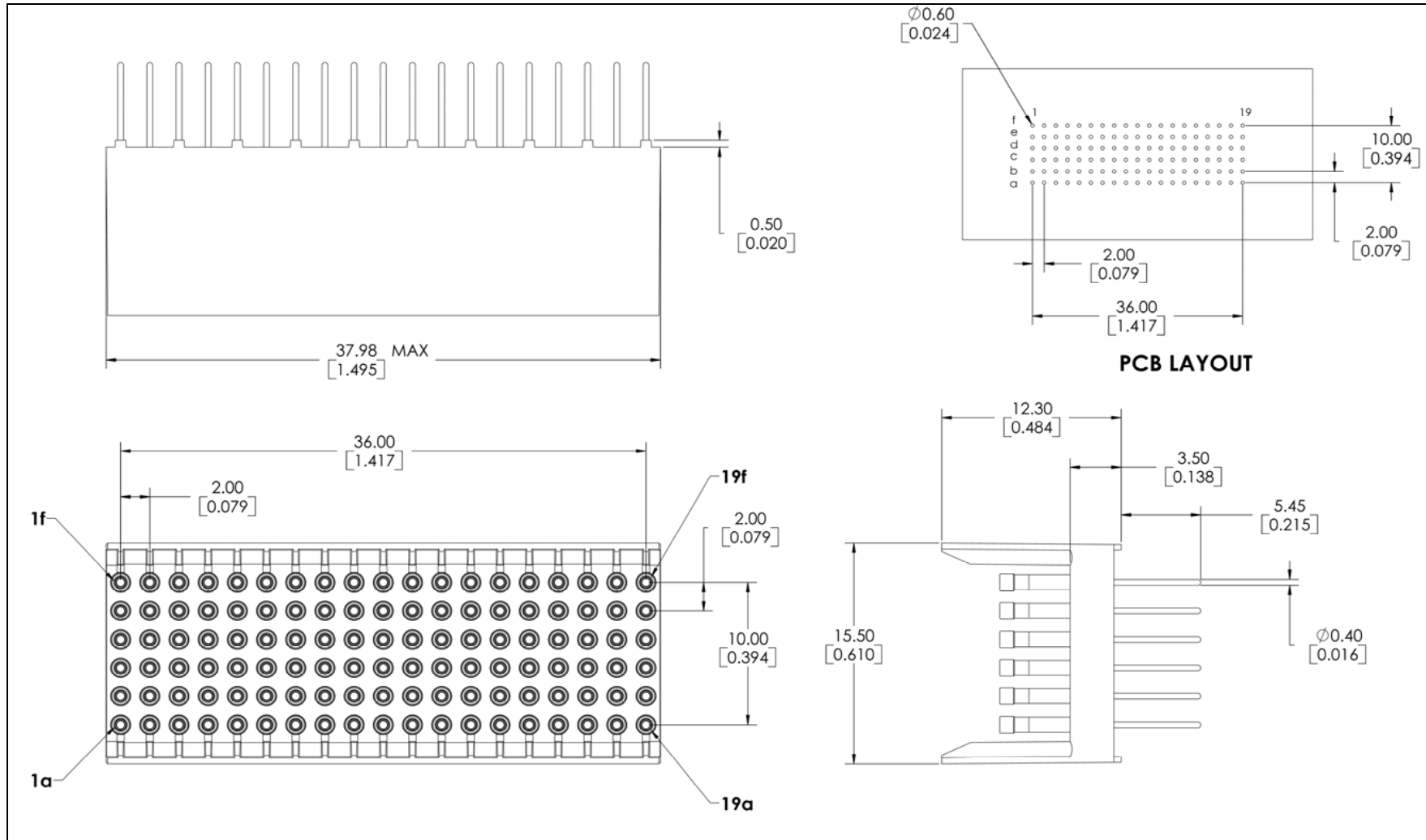

Figure 6. Female Motherboard Backplane Connector, 311P822-FC-095-B(X)-D(X)
95 Socket Contacts, Style B

(Note: Actual solder tail length shall be as specified in 1.3.3, and is referenced from connector standoff.)

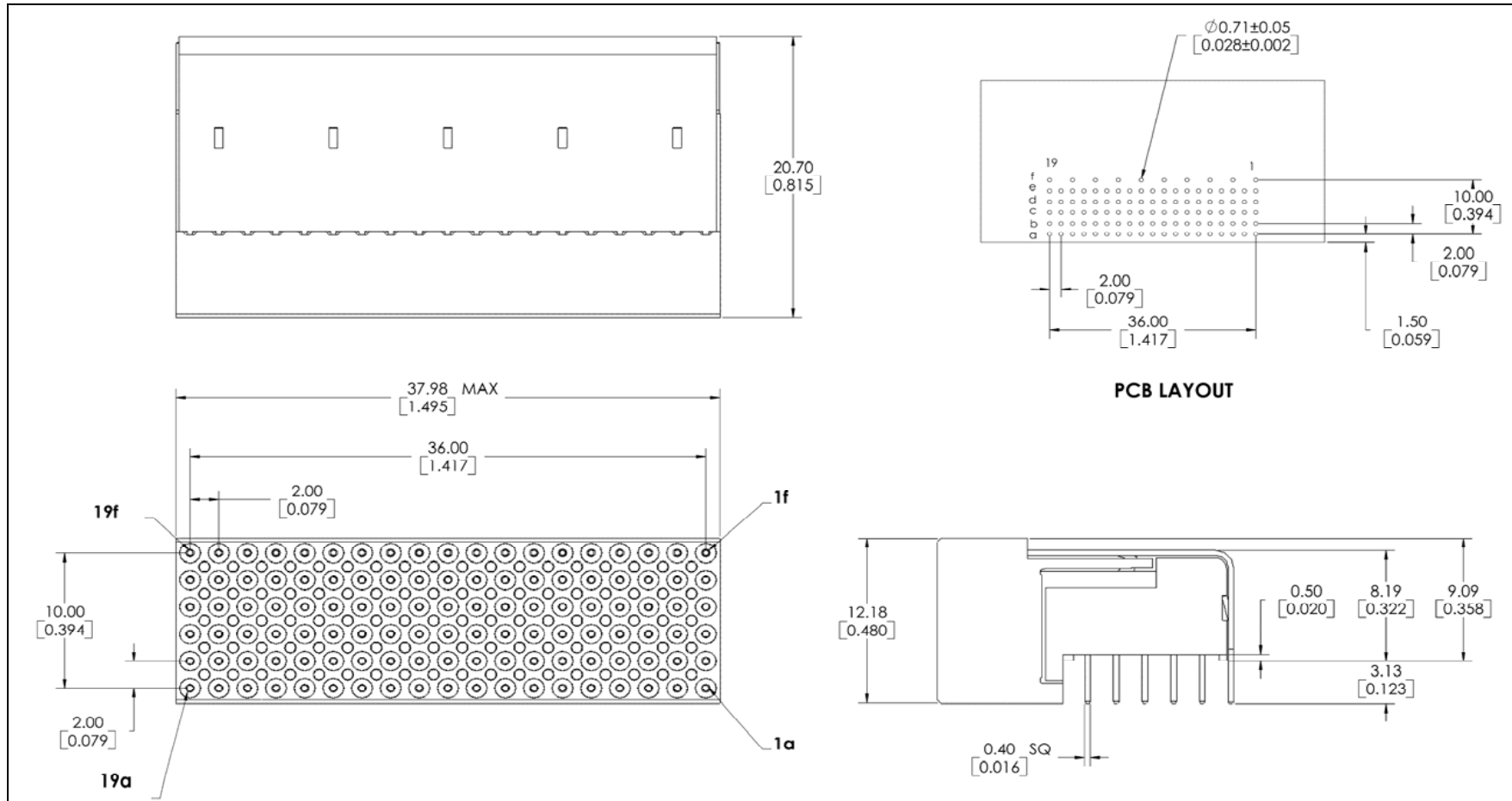

Figure 7. Male Daughterboard Connector, 311P822-MC-095-B(X)-D(X)
Right Angle, 95 Pin Contacts, Style B

(Note: Actual solder tail length shall be as specified in 1.3.3, and is referenced from connector standoff.)

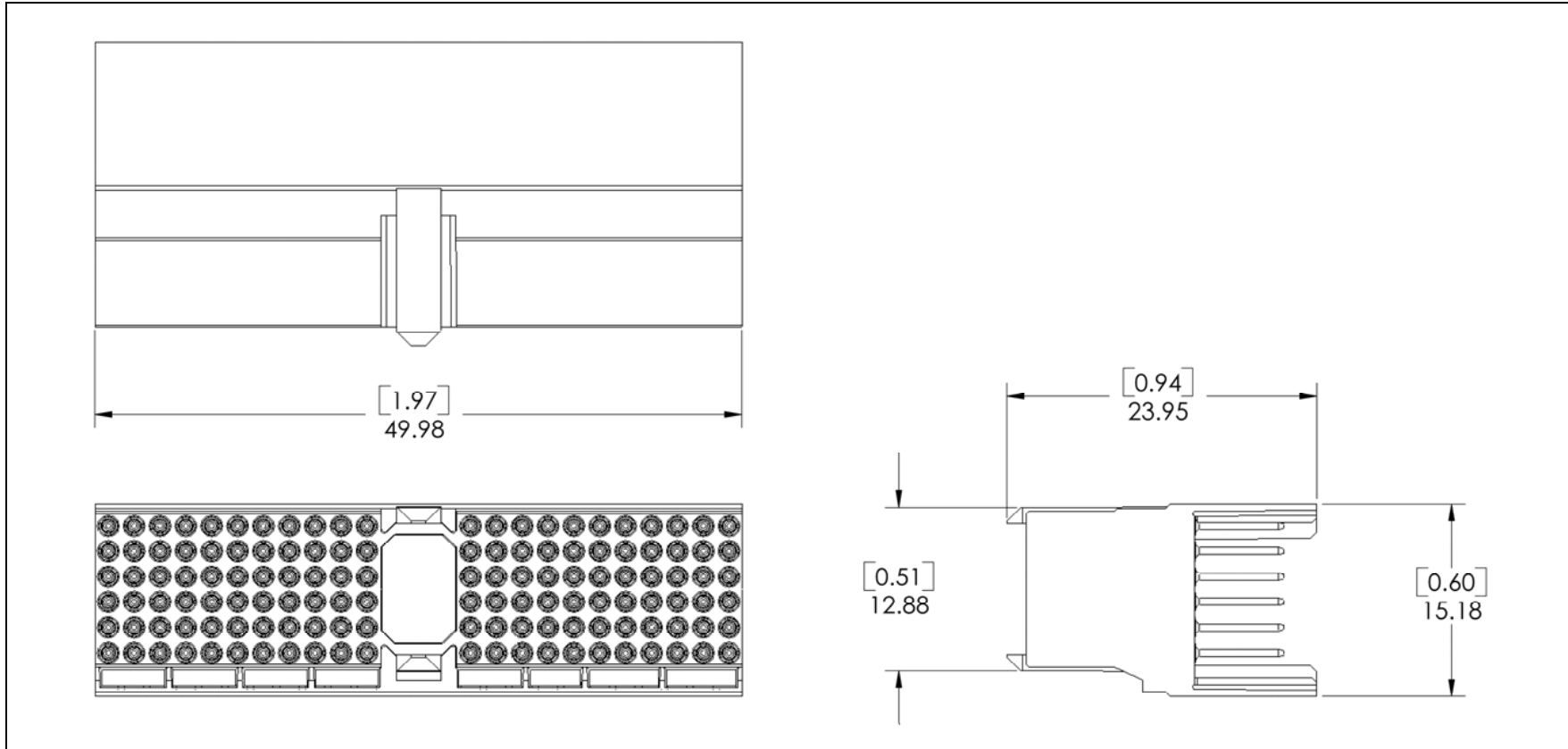

Figure 8. Adapter Connector, 311P822-FA-110-A
 110 Contacts, Style A; Mates 311P822 Female Motherboard Connector to Commercial cPCI™ Daughterboard Connector

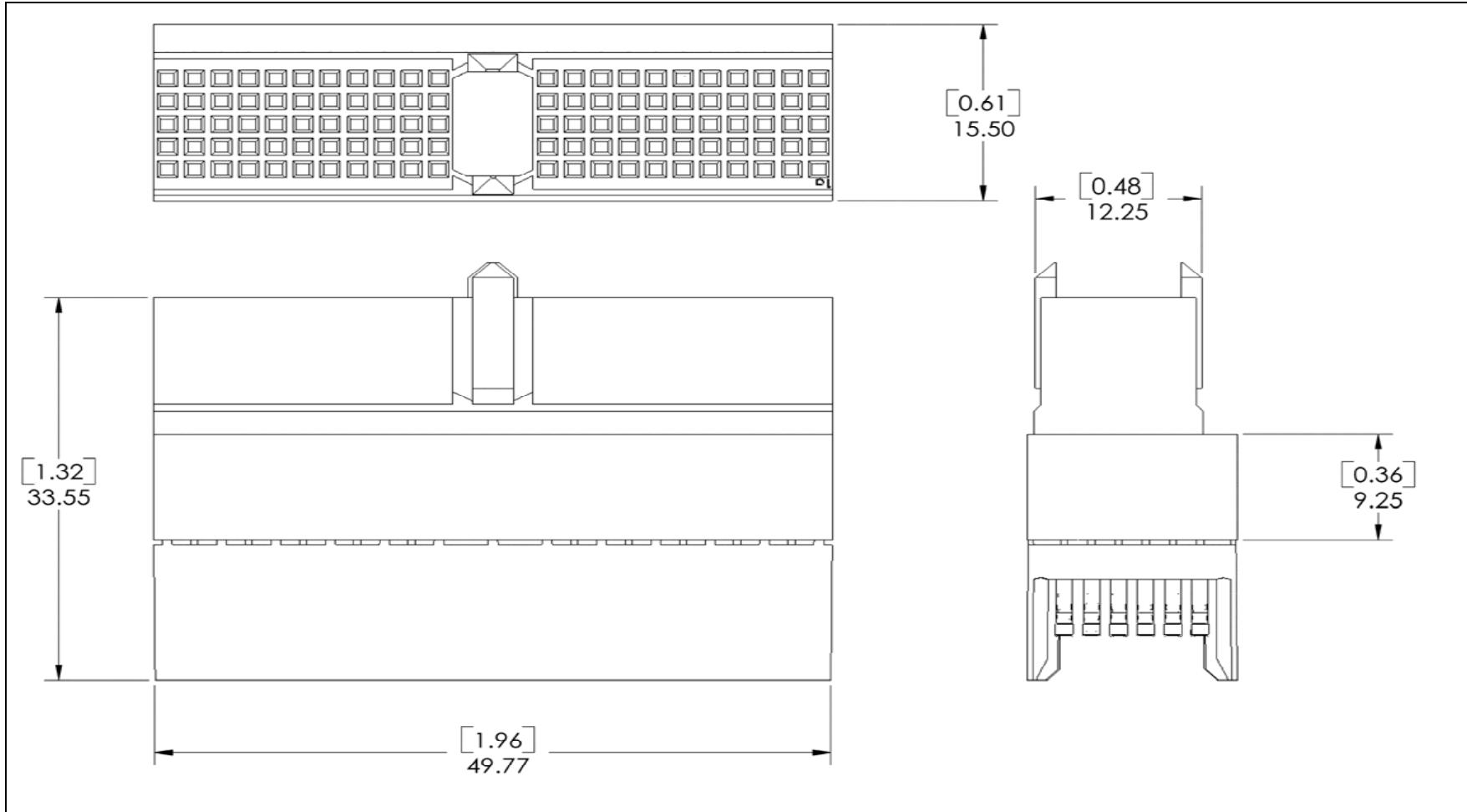

Figure 9. Adapter Connector, 311P822-MA-110-A
 110 Contacts, Style A; Mates 311P822 Male Daughterboard Connector to Commercial cPCI™ Motherboard Connector

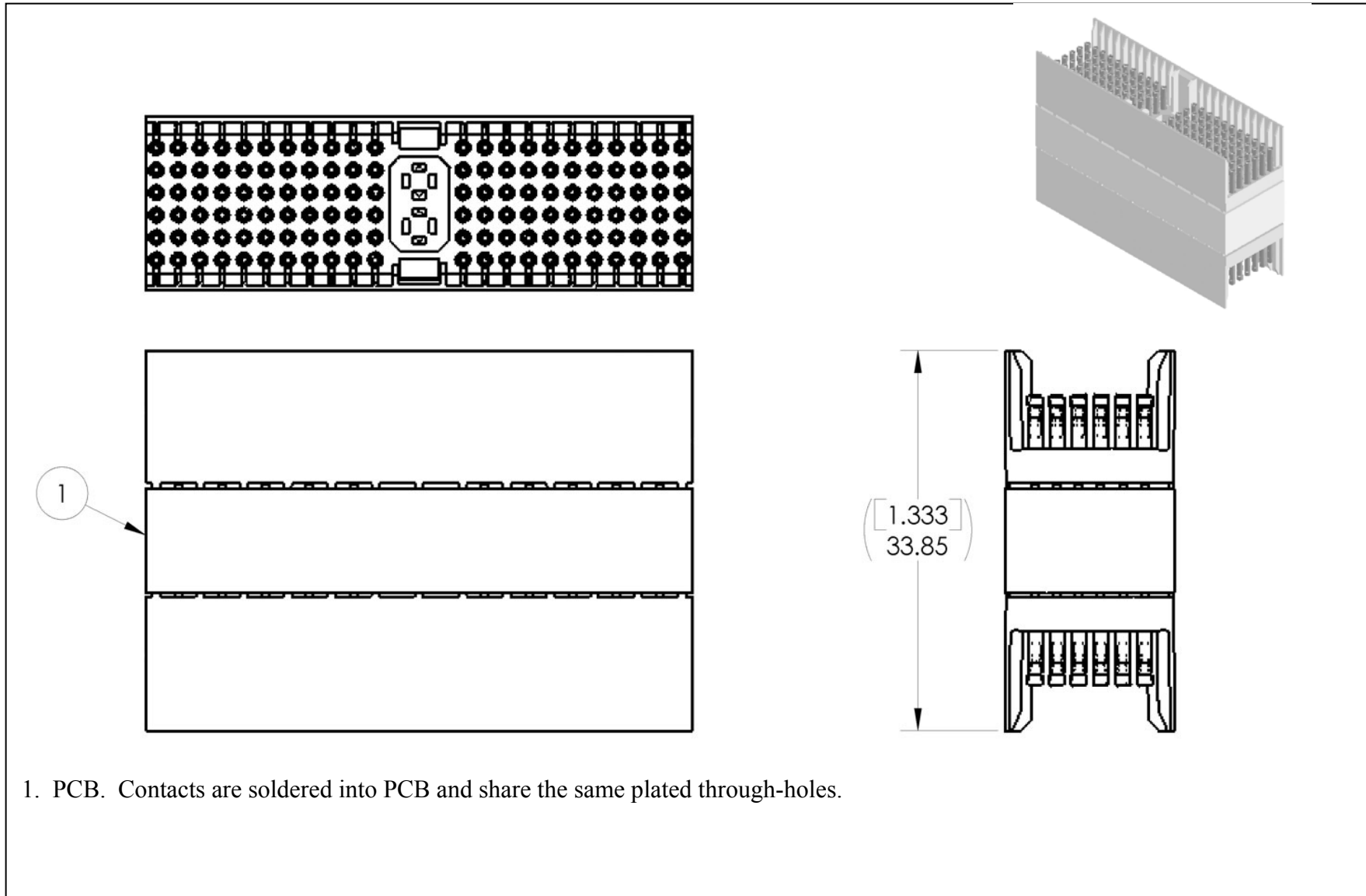

Figure 10. Adapter Connector 311P822-FFA-110-A
 110 Contacts, Style A; Mates Two 311P822 Male Daughterboard Connectors Together

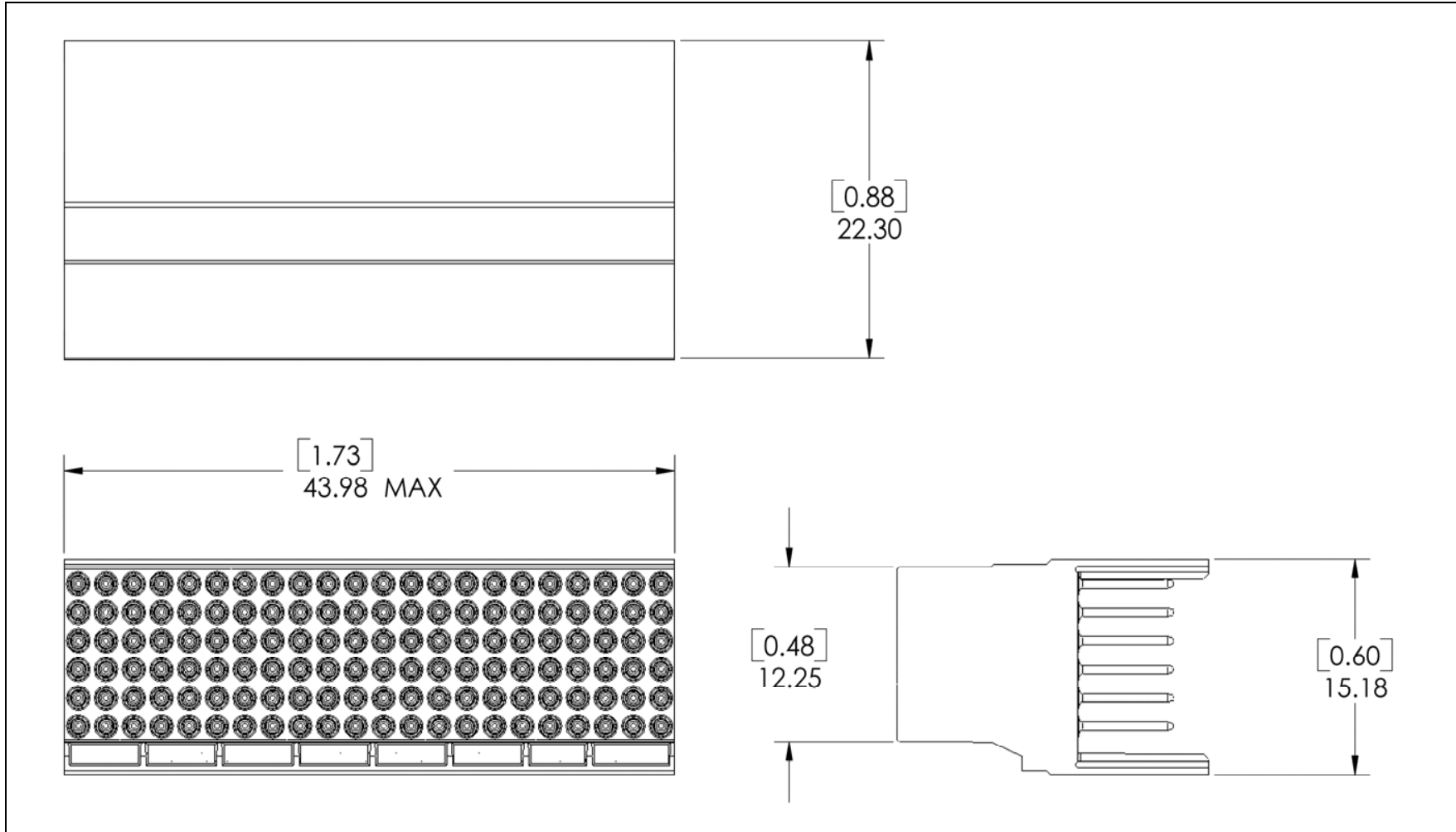

Figure 11. Adapter Connector 311P822-FA-110-B
 110 Contacts, Style B; Mates 311P822 Female Motherboard Connector to Commercial cPCI™ Daughterboard Connector

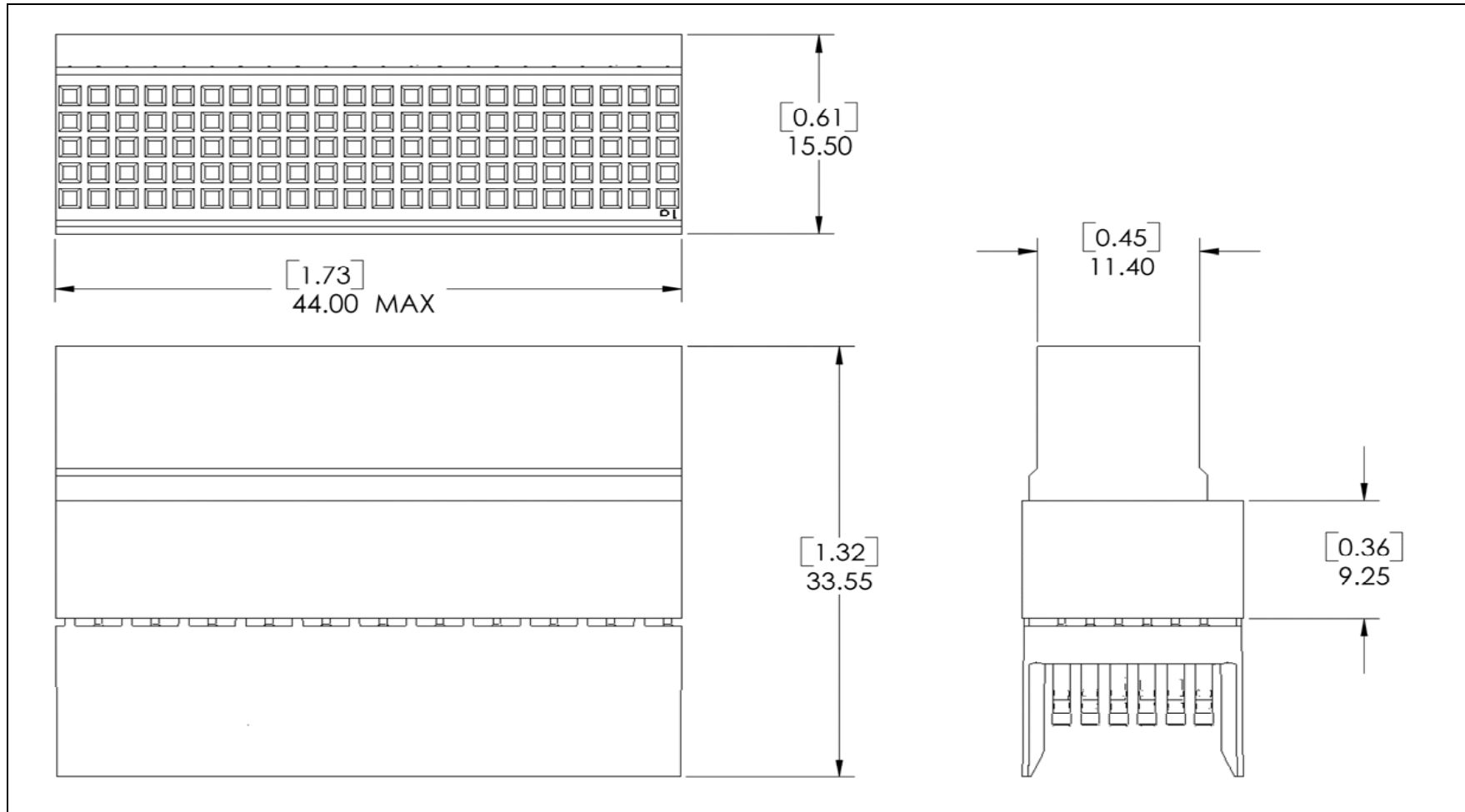

Figure 12. Adapter Connector, 31P822-MA-110-B
 110 Contacts, Style B; Mates 311P822 Male Daughterboard Connector to Commercial cPCI™ Motherboard Connector

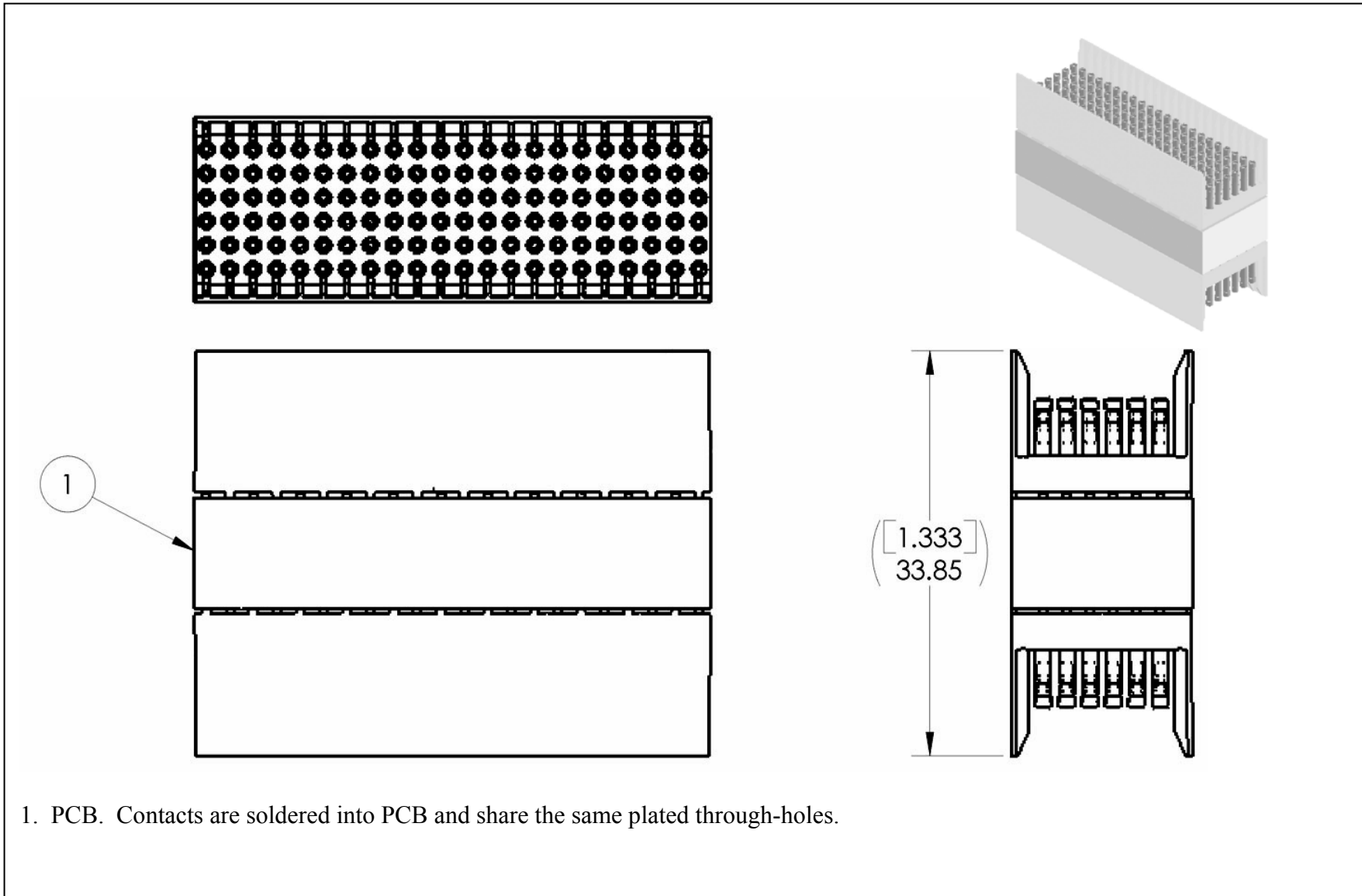

Figure 13. Adapter Connector 311P822-FFA-110-B
 110 Contacts, Style B; Mates Two 311P822 Male Daughterboard Connectors Together

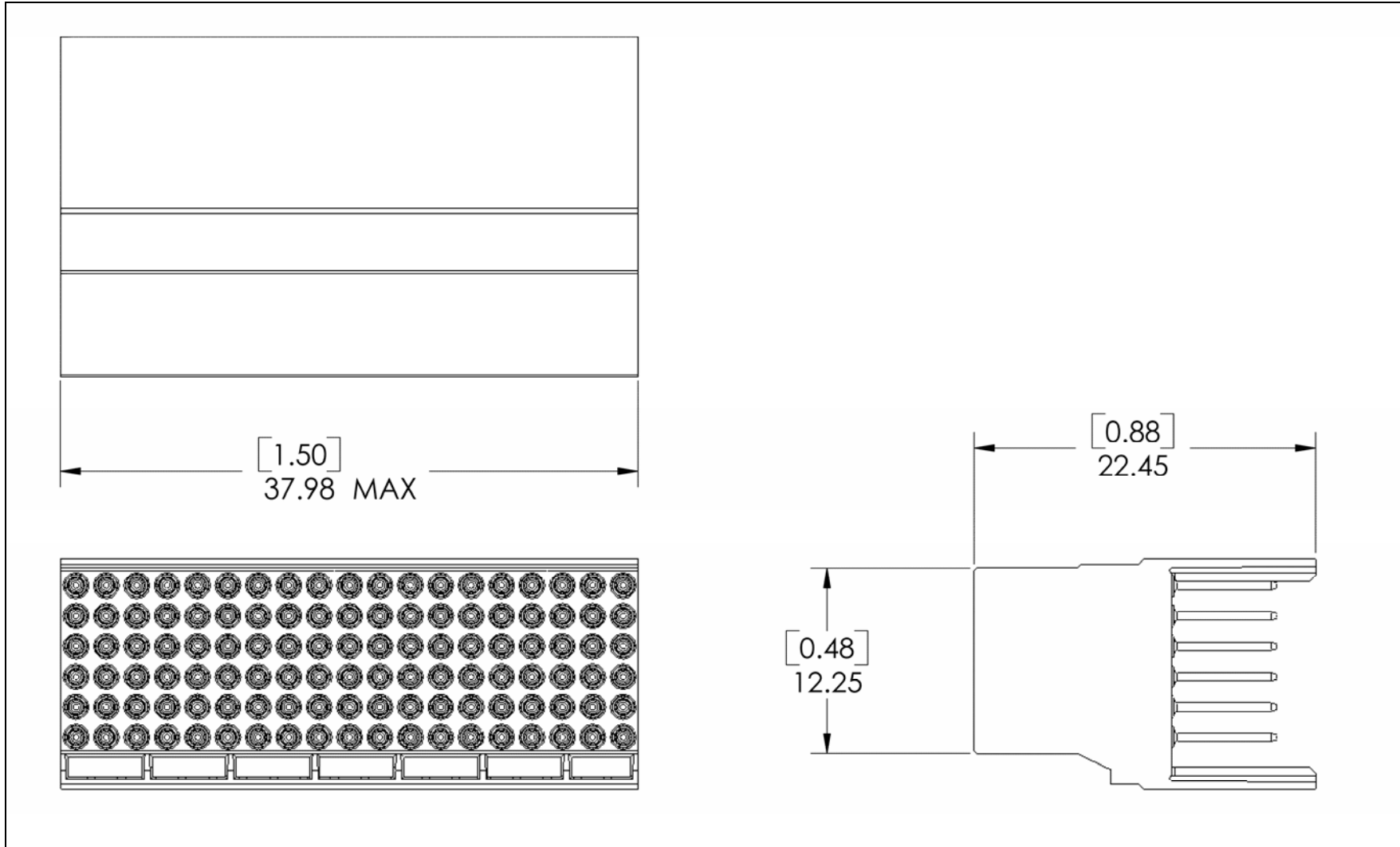

Figure 14. Adapter Connector, 311P822-FA-095-B
 95 Contacts, Style B; Mates 311P822 Female Motherboard Connector to Commercial cPCI™ Daughterboard Connector

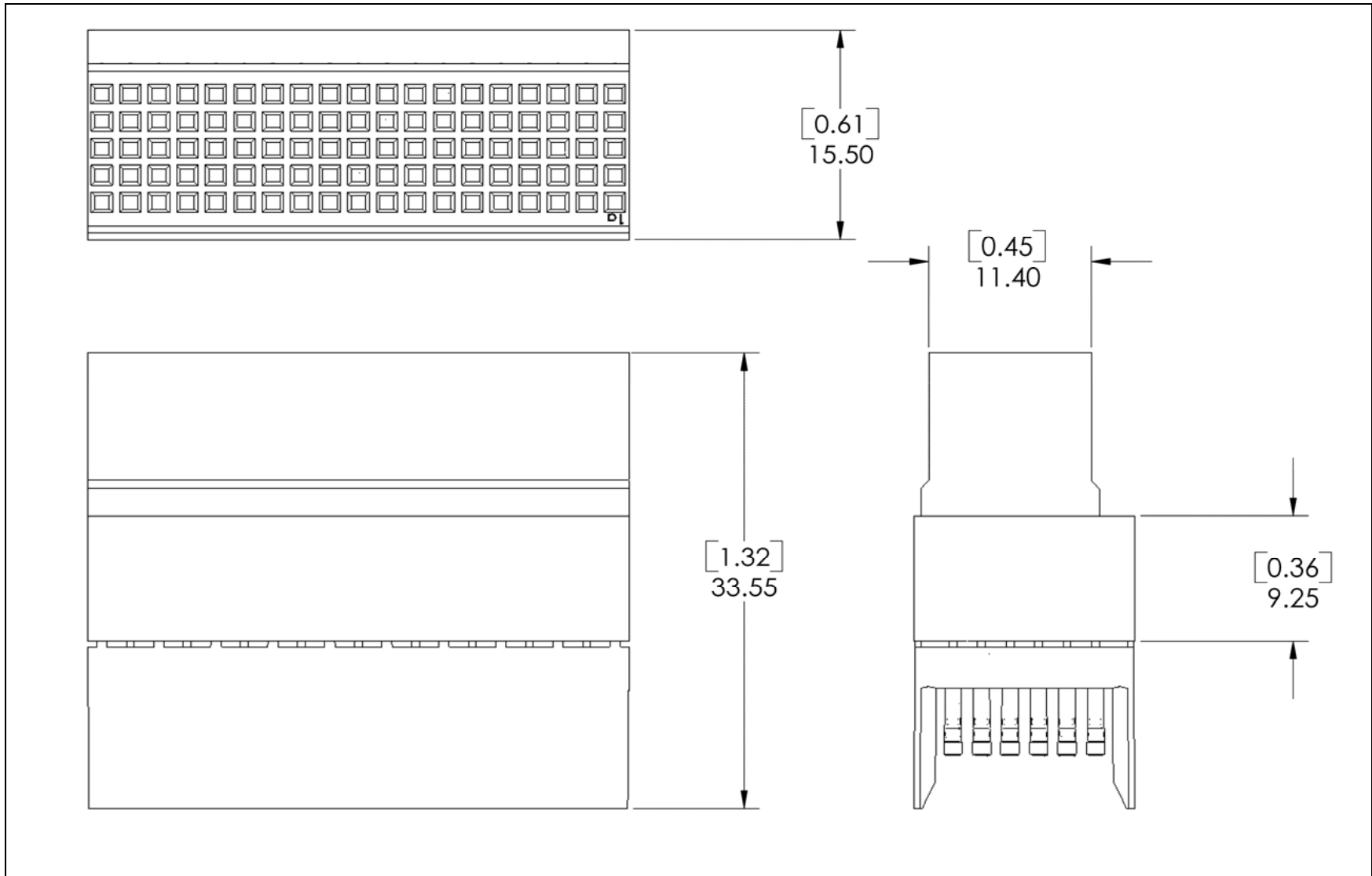

Figure 15. Adapter Connector, 311P822-MA-095-B
 95 Contacts, Style B; Mates 311P822 Male Daughterboard Connector to Commercial cPCI™ Motherboard Connector

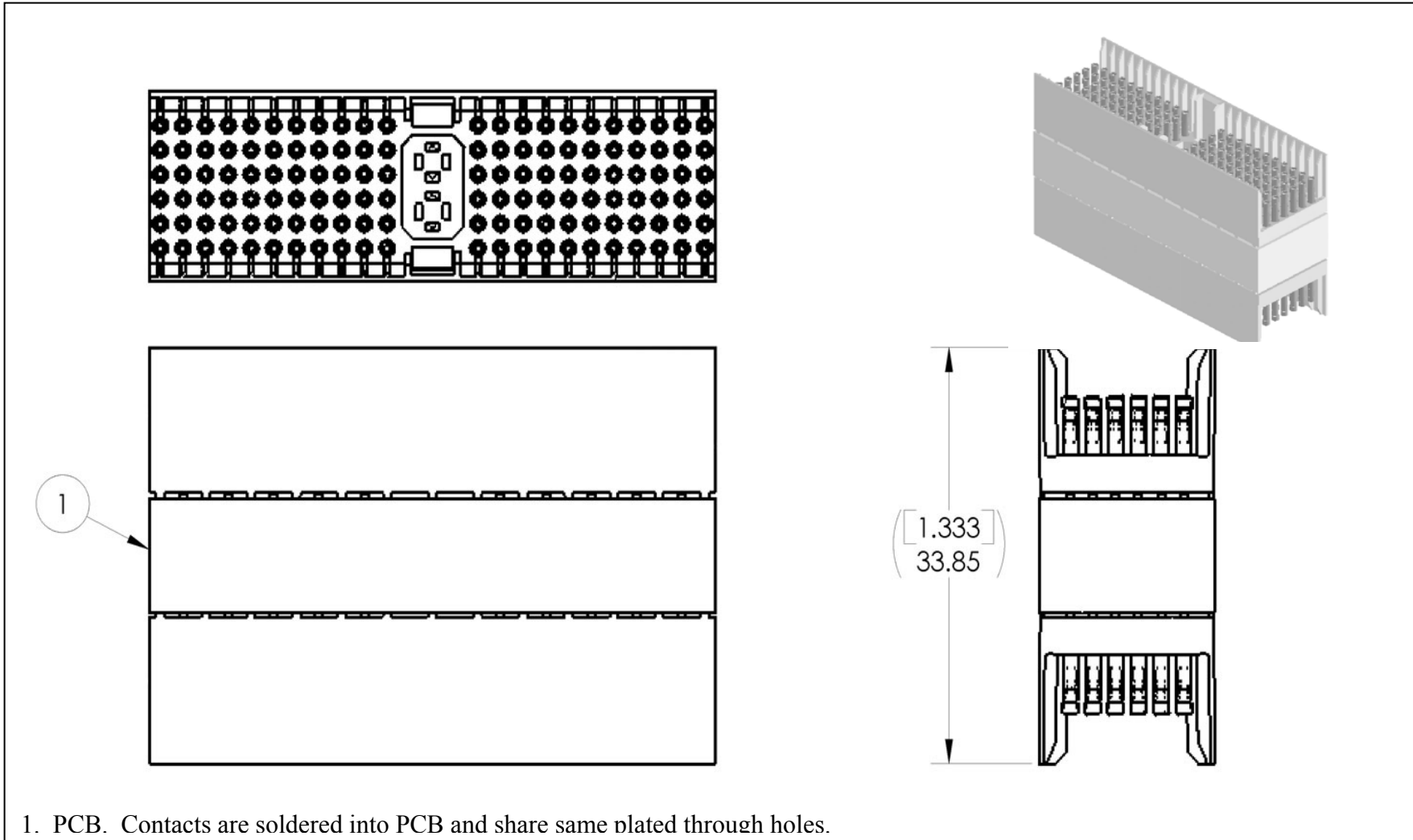

Figure 16. Adapter Connector 311P822-FFA-095-B
 95 Contacts, Style B; Mates Two 311P822 Male Daughterboard Connectors Together

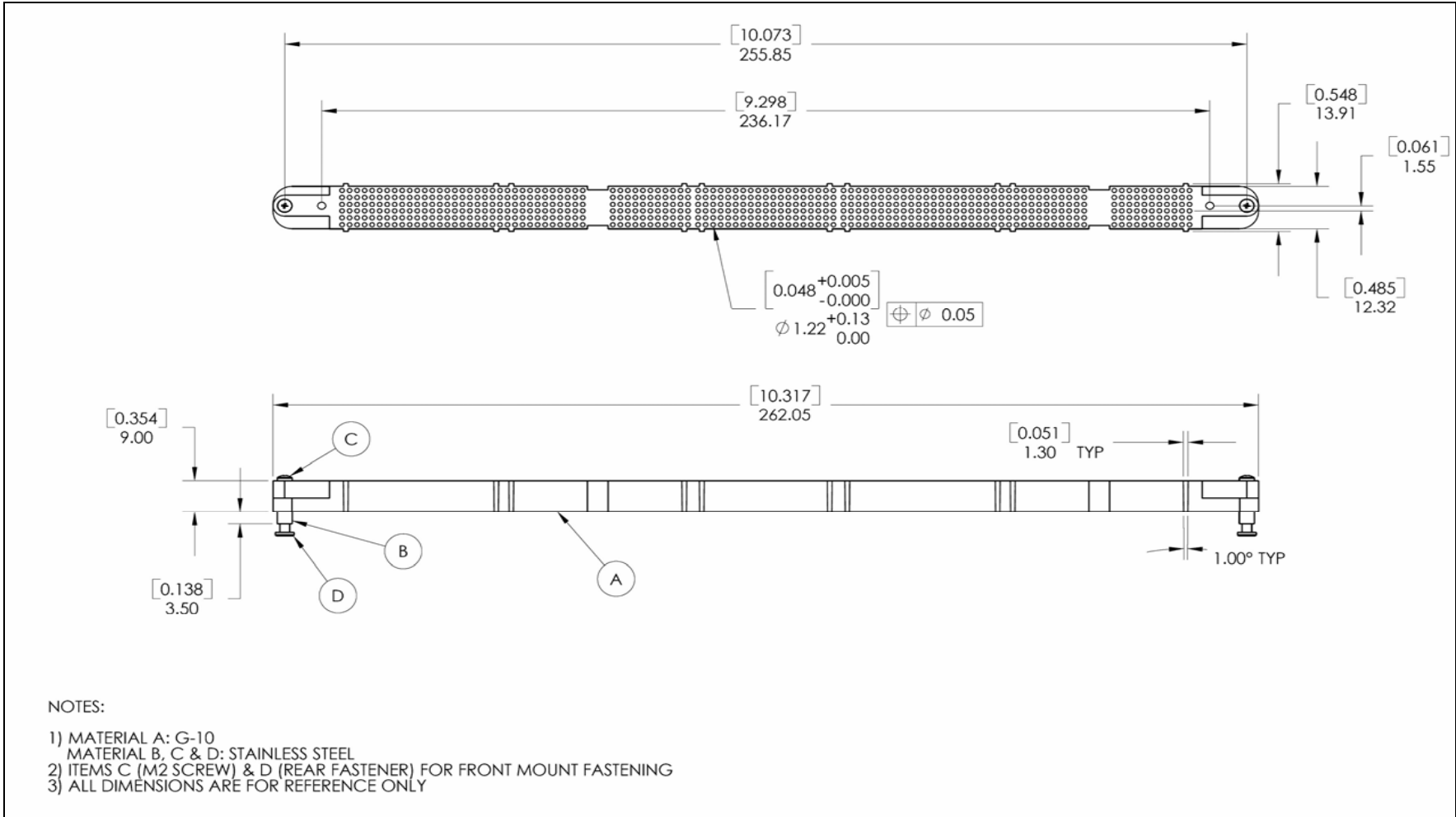

Figure 17. Backplane Motherboard Soldering Fixture 311P822-MF

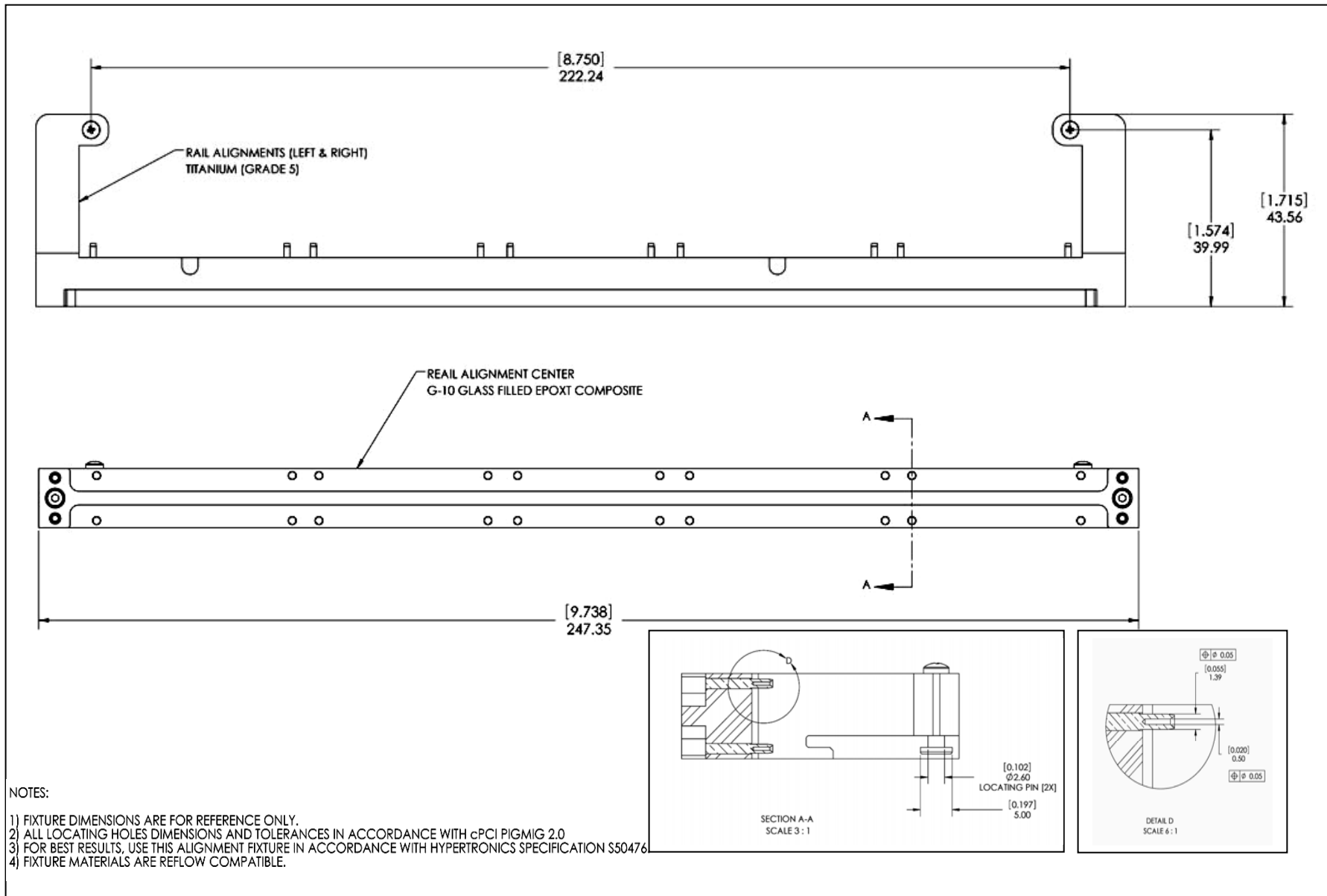

Figure 18. Daughterboard (Free Board) Soldering Fixture 311P822-DF

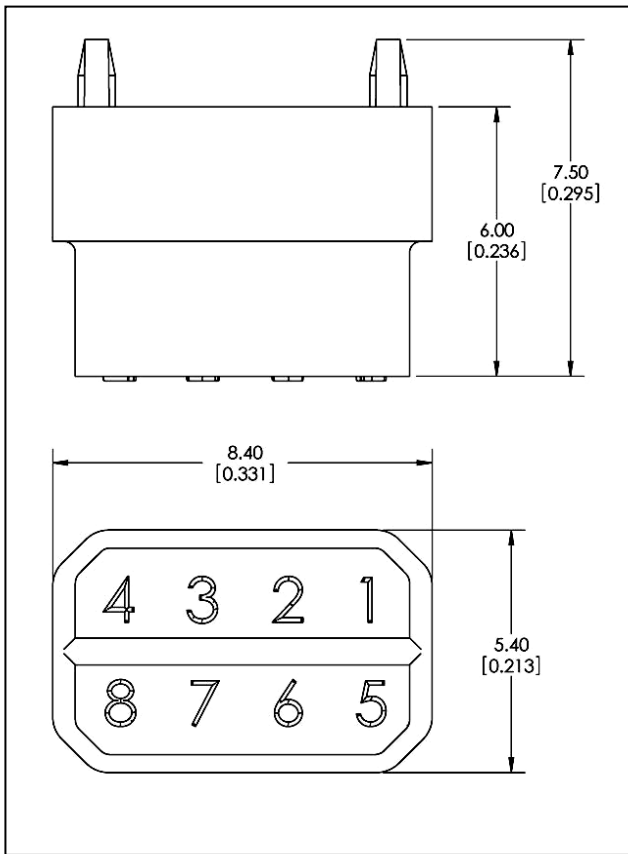

Fig 16A: Overall dimensions of male key and code layout

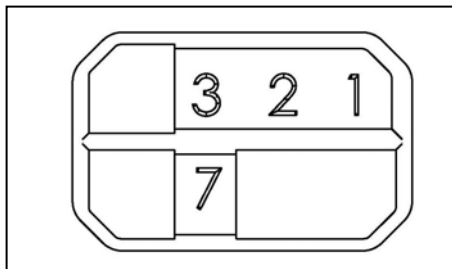

Fig 16B: Example diagram for key code 1237
(311P822-MK-04;
Mates with female key code 4568)

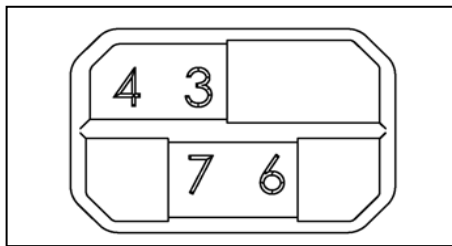

Fig 16C: Example diagram for key code 3467
(311P822-MK-59;
Mates with female key code 1258)

Note: Numbered pin positions stand above the key face, and unnumbered positions are recessed below the key face to accept mating key's pin positions.

Male Key Code	Corresponding Goddard No.
1234	311P822-MK-01
1236	311P822-MK-03
1237	311P822-MK-04
1238	311P822-MK-05
1246	311P822-MK-07
1247	311P822-MK-08
1268	311P822-MK-14
1345	311P822-MK-16
1348	311P822-MK-19
1357	311P822-MK-21
1358	311P822-MK-22
1378	311P822-MK-25
1457	311P822-MK-27
1467	311P822-MK-29
1478	311P822-MK-31
1568	311P822-MK-33
1678	311P822-MK-35
2346	311P822-MK-37
3467	311P822-MK-59
3478	311P822-MK-61
4678	311P822-MK-69

Fig 16D: Available male key codes

Figure 19. 311P822-MKXX, MPC Male Key

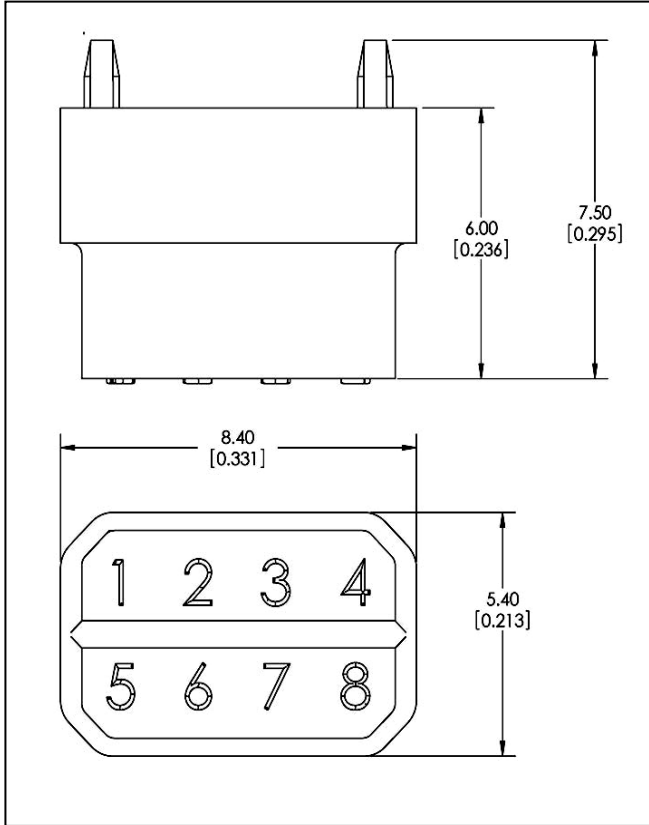

Fig 17A: Overall dimensions of female key and code layout

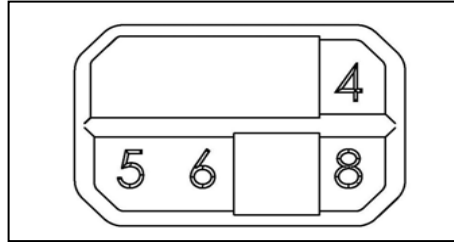

Fig 17B: Example diagram for key code 4568
(311P822-FK-04;
Mates with male key code 1237)

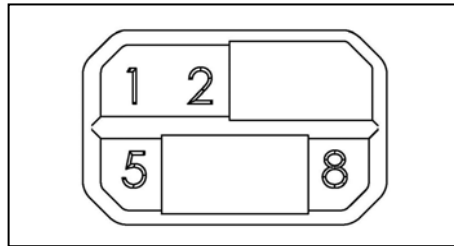

Fig 17C: Example diagram for key code 1258
(311P822-FK-59;
Mates with male key code 3467)

Note: Numbered pin positions stand above the key face, and unnumbered positions are recessed below the key face to accept mating key's pin positions.

Female Key Code	Corresponding Goddard No.
5678	311P822-FK-01
4578	311P822-FK-03
4568	311P822-FK-04
4567	311P822-FK-05
3578	311P822-FK-07
3568	311P822-FK-08
3457	311P822-FK-14
2678	311P822-FK-16
2567	311P822-FK-19
2468	311P822-FK-21
2467	311P822-FK-22
2456	311P822-FK-25
2368	311P822-FK-27
2358	311P822-FK-29
2356	311P822-FK-31
2347	311P822-FK-33
2345	311P822-FK-35
1578	311P822-FK-37
1258	311P822-FK-59
1256	311P822-FK-61
1235	311P822-FK-69

Fig 17D: Available female key codes

Figure 20. 311P822-FK-XX, MPC Female Key

Table IV. Cross Reference of GSFC to Vendor Similar Part Number

Approved Source of Supply:

Hypertronics Corp.
Hudson, MA 01749

CAGE Code: 50541

	Goddard Number	Similar Hypertronics Number
110 Contact Connectors	311P822-FC-110-AG-D	K2A110FFDTAH
	311P822-FC-110-AS-D	K2A110FFDTABH
	311P822-MC-110-AG-D	K2A110FMDTH
	311P822-MC-110-AS-D	K2A110FMDTBH
	311P822-FC-110-BG-D	K2B110FFDTAH
	311P822-FC-110-BS-D	K2B110FFDTABH
	311P822-MC-110-BG-D	K2B110FMDTH
	311P822-MC-110-BS-D	K2B110FMDTBH
	311P822-FC-110-AG-D2	K2A110FFD2TAH
	311P822-FC-110-AS-D2	K2A110FFD2TABH
	311P822-FC-110-BG-D2	K2B110FFD2TAH
	311P822-FC-110-BS-D2	K2B110FFD2TABH
	311P822-FC-110-AG-D4	K2A110FFD4TAH
	311P822-FC-110-AS-D4	K2A110FFD4TABH
	311P822 MC-110-AG-D4	K2A110FMD4TH
	311P822 MC-110-AS-D4	K2A110FMD4TBH
	311P822-FC-110-BG-D4	K2B110FFD4TAH
	311P822-FC-110-BS-D4	K2B110FFD4TABH
	311P822 MC-110-BG-D4	K2B110FMD4TH
	311P822 MC-110-BS-D4	K2B110FMD4TBH

Table IV (Continued). Cross Reference of GSFC to Vendor Similar Part Number

	Goddard Number	Similar Hypertronics Number
95 Contact Connectors	311P822-FC-095-BG-D	K2B095FFDTAH
	311P822-FC-095-BS-D	K2B095FFDTABH
	311P822-MC-095-BG-D	K2B095FMDTH
	311P822-MC-095-BS-D	K2B095FMDTBH
	311P822-FC-095-BG-D2	K2B095FFD2TAH
	311P822-FC-095-BS-D2	K2B095FFD2TABH
	311P822-MC-095-BG-D4	K2B095FMD4TH
	311P822-MC-095-BS-D4	K2B095FMD4TBH
	311P822-FC-095-BG-D4	K2B095FFD4TAH
	311P822-FC-095-BS-D4	K2B095FFD4TABH
110 Contact Adapter Connectors	311P822-FA-110-A	K2A110-0001
	311P822-MA-110-A	K2A110-0002
	311P822-FFA-110-A	K2A110-0004
	311P822-FA-110-B	K2B110-0001
	311P822-MA-110-B	K2B110-0002
	311P822-FFA-110-B	K2B110-0004
95 Contact Adapter Connectors	311P822-FA-095-B	K2B095-0001
	311P822-MA-095-B	K2B095-0002
	311P822-FFA-095-B	K2B095-0004
Assembly Fixtures	311P822-BPF	T-2066
	311P822-DCF	T-2082

Table IV (Continued). Cross Reference of GSFC to Vendor Similar Part Number

	Goddard Number	Similar Hypertronics Number
Male MPC Keys (Optional)	311P822-MK-01	ZK2000-002-01
	311P822-MK-03	ZK2000-002-03
	311P822-MK-04	ZK2000-002-04
	311P822-MK-05	ZK2000-002-05
	311P822-MK-07	ZK2000-002-07
	311P822-MK-08	ZK2000-002-08
	311P822-MK-14	ZK2000-002-14
	311P822-MK-16	ZK2000-002-16
	311P822-MK-19	ZK2000-002-19
	311P822-MK-21	ZK2000-002-21
	311P822-MK-22	ZK2000-002-22
	311P822-MK-25	ZK2000-002-25
	311P822-MK-27	ZK2000-002-27
	311P822-MK-29	ZK2000-002-29
	311P822-MK-31	ZK2000-002-31
	311P822-MK-33	ZK2000-002-33
	311P822-MK-35	ZK2000-002-35
	311P822-MK-37	ZK2000-002-37
	311P822-MK-59	ZK2000-002-59
311P822-MK-61	ZK2000-002-61	
311P822-MK-69	ZK2000-002-69	

Table IV (Continued). Cross Reference of GSFC to Vendor Similar Part Number

	Goddard Number	Similar Hypertronics Number
Female MPC Keys (Optional)	311P822-FK-01	ZK2000-001-01
	311P822-FK-03	ZK2000-001-03
	311P822-FK-04	ZK2000-001-04
	311P822-FK-05	ZK2000-001-05
	311P822-FK-07	ZK2000-001-07
	311P822-FK-08	ZK2000-001-08
	311P822-FK-14	ZK2000-001-14
	311P822-FK-16	ZK2000-001-16
	311P822-FK-19	ZK2000-001-19
	311P822-FK-21	ZK2000-001-21
	311P822-FK-22	ZK2000-001-22
	311P822-FK-25	ZK2000-001-25
	311P822-FK-27	ZK2000-001-27
	311P822-FK-29	ZK2000-001-29
	311P822-FK-31	ZK2000-001-31
	311P822-FK-33	ZK2000-001-33
	311P822-FK-35	ZK2000-001-35
	311P822-FK-37	ZK2000-001-37
	311P822-FK-59	ZK2000-001-59
311P822-FK-61	ZK2000-001-61	
311P822-FK-69	ZK2000-001-69	