

# HISTORY OF SPACEFLIGHT CONNECTORS

By: Dr. Tracee L. Jamison, Code 562, NASA GSFC  
February 2007

## Connector Basics

Optical fibers transmit light and they are made of glass, which make them very sensitive to light loss when connected to other fibers or breakage when handled too roughly. Connectors are used to terminate optical fibers in much the same way as electrical plugs are used. They not only must provide transparency so as to limit light loss and back reflection but they must also be sturdy enough so that the fiber can be integrated into networks or interconnected with other fibers. For this, no other area of fiber optics has been given more attention than termination. Connectors can mate two fibers to create a temporary joint and/or connect an optical fiber to a piece of network. These terminations must be of the right style, installed in a manner that makes them have little light loss and protected against dirt or damage in use. Since fiber optic technology was introduced in the late 70s, numerous connector styles have been developed. Each new design was meant to offer better performance (less light loss and back reflection), easier and/or termination and lower cost. Figure 1 illustrates an example of a connector. Connectors vary in design and component technologies.

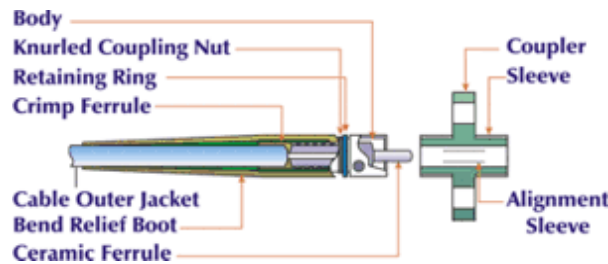

Figure 1. Example of a basic connector

1. **The Ferrule** - this is a thin structure (often cylindrical) that actually holds the glass fiber. It has a hollowed-out center that forms a tight grip around the fiber. Ferrules are usually made from ceramic, metal, or high-quality plastic, and will typically hold one strand of fiber. The ferrule is bored through the center at a diameter that is slightly larger than the diameter of the fiber cladding. The ferrule acts as a fiber alignment mechanism. The end of the fiber is located at the end of the ferrule.
2. **The Connector Body** - this is a plastic or metal structure that holds the ferrule and attaches to the jacket and strength members of the fiber cable itself. It is usually constructed of metal or plastic and includes one or more assembled pieces which hold the fiber in place. The details of these connector body assemblies vary among connectors, but bonding and/or crimping is commonly used to attach strength members and cable jackets to the connector body. The ferrule extends past the connector body to slip into the coupling device.

3. **The Cable** - The cable is attached to the connector body. It acts as the point of entry for the fiber. Typically, a strain-relief boot is added over the junction between the cable and the connector body, providing extra strength to the junction.
4. **The Coupling Device** - this is a part of the connector body that holds the connector in place when it gets attached to another device (a switch, NIC, bulkhead coupler, etc.). It may be a latch clip, a bayonet-style nut, or similar device. Most fiber optic connectors do not use the male-female configuration common to electronic connectors. Instead, a coupling device such as an alignment sleeve is used to mate the connectors. Similar devices may be installed in fiber optic transmitters and receivers to allow these devices to be mated via a connector. These devices are also known as feed-through bulkhead adapters.

### **Connector Loss Mechanisms**

Connector loss is caused by a number of factors. Loss is minimized when the two fiber cores are identical and perfectly aligned and the connectors are properly finished and no dirt is present. Only the light that is coupled into the receiving fiber's core will propagate, so all the rest of the light becomes the connector or splice loss.

End gaps cause two problems, insertion loss and return loss. The emerging cone of light from the connector will spill over the core of the receiving fiber and be lost. In addition, air gap between fibers causes a reflection when the light encounters the change in refractive index from the glass fiber to the air in the gap. This reflection (called fresnel reflection) amounts to about 5% in typical flat polished connectors, and means that no connector with an air gap can have less than 0.3 dB loss. This reflection is also referred to as back reflection or optical return loss, which can be a problem in laser based systems. Connectors use a number of polishing techniques to insure physical contact (PC) of the fiber ends to minimize back reflection.

The end finish of the fiber must be properly polished to minimize loss. A rough surface will scatter light and dirt can scatter and absorb light. Since the optical fiber is so small, typical airborne dirt can be a major source of loss.

Two sources of loss are directional; numerical aperture (NA) and core diameter. Differences in these two will create connections that have different losses depending on the direction of light propagation. Light from a fiber with a larger NA will be more sensitive to angularity and end gap, so transmission from a fiber of larger NA to one of smaller NA will be higher loss than the reverse. Likewise, light from a larger fiber will have high loss coupled to a fiber of smaller diameter, while one can couple a small diameter fiber to a large diameter fiber with minimal loss, since it is much less sensitive to end gap or lateral offset.

### **Connector Ferrule Shapes & Polishes**

Fiber optic connectors can have several different ferrule shapes or finishes, usually referred to as polishes (See Figure 2). Early connectors, because they did not have keyed

ferrules and could rotate in mating adapters, always had an air gap between the connectors to prevent them from rotating and grinding scratches into the ends of the fibers.

Beginning with the ST and FC which had keyed ferrules, the connectors were designed to contact tightly, what we now call physical contact (PC) connectors. Reducing the air gap reduced the loss and back reflection (very important to laser-based singlemode systems), since light has a loss of about 5% (~0.25 dB) at each air gap and light is reflected back up the fiber. While air gap connectors usually had losses of 0.5 dB or more and return loss of 20 dB, PC connectors had typical losses of 0.3 dB and a return loss of 30 to 40 dB.

Soon thereafter, it was determined that making the connector ferrules convex would produce an even better connection. The convex ferrule guaranteed the fiber cores were in contact. Losses were under 0.3dB and return loss 40 dB or better. The final solution for singlemode systems extremely sensitive to reflections, like CATV or high bit rate telco links, was to angle the end of the ferrule 8 degrees to create what an APC or angled PC connector. Then any reflected light is at an angle that is absorbed in the cladding of the fiber.

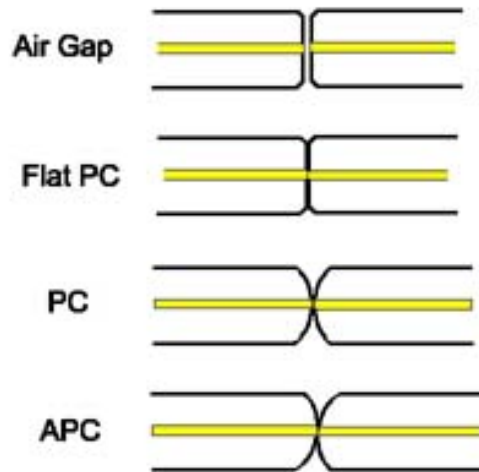

Figure 2. Types of Polishing

## Timeline of Spaceflight Connectors

Table 1. Spaceflight Connectors used at NASA

Mission	Dates	Connector Type	Agency
Sampex	3-Jul-92	38999/29504	NASA GSFC
XTE	30-Dec-95	38999/29504	NASA GSFC

EO-1	21-Nov-00	38999/29504	NASA GSFC
ISS	20-Nov-98 30-Jun-01	38999/29504	International Space Community
MAP		Johanson FC	
Experiment Pyrolaser on Demeter		Johanson FC	CNES Toulouse (French Space Agency)
Mars Science Lab		Johanson FC	JPL
EO-1	21-Nov-00	MTP	NASA GSFC
GLAS	12-Jan-03	Diamond AVIMS	NASA GSFC
MLA	30-Jul-04	Diamond AVIMS	NASA GSFC
Tropospheric Emission Spectromoter (TES)	5-Oct-06	Diamond AVIMS	JPL
LOLA	Oct-08	Diamond AVIMS	NASA GSFC

Table 2. Timeline of Spaceflight Connectors used at NASA

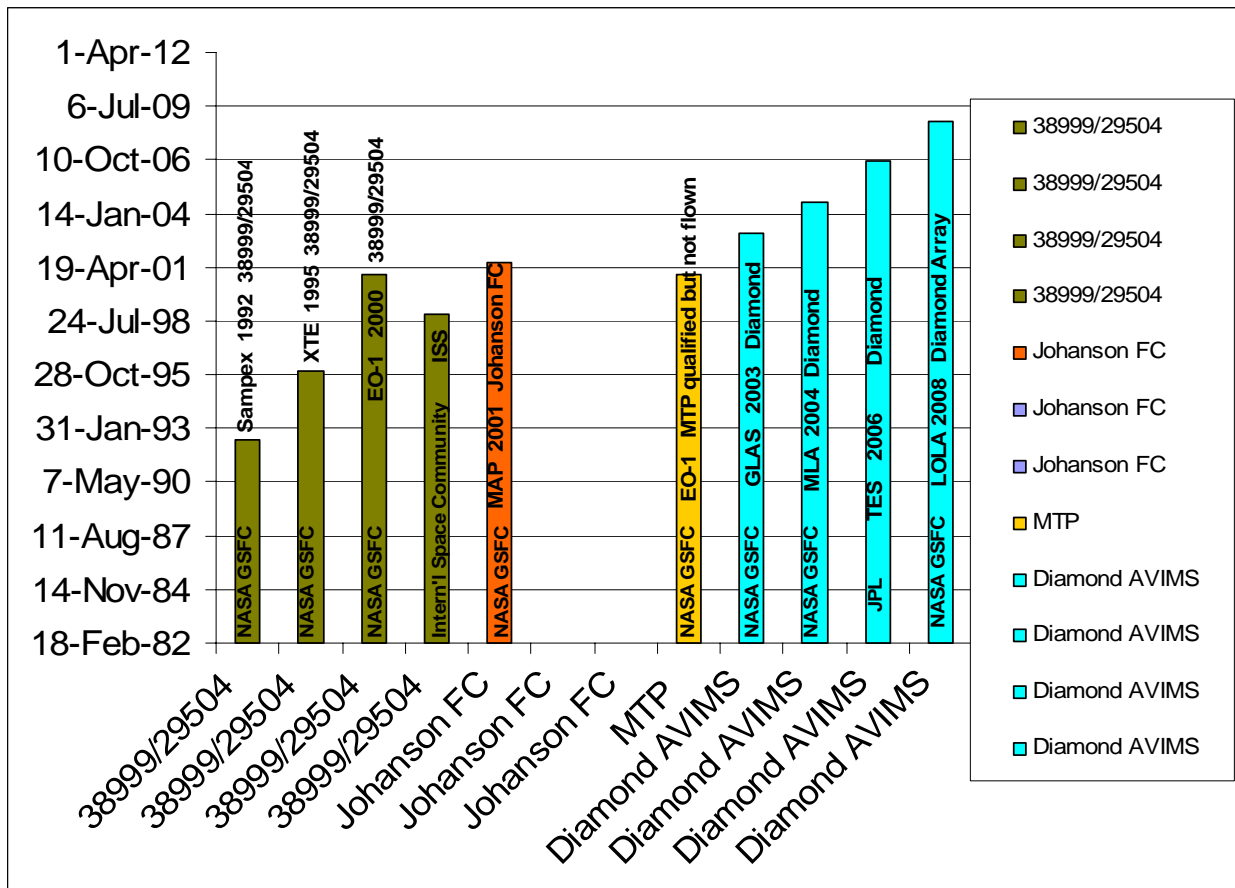

## ***Types of Commercial Connectors***

### **SMA Connector**

The SMA connector was the original standard for fiber termination but it is now obsolete for many applications, especially in fiber-fiber connections as the fiber can rotate in the connector and there is no physical contact. Also, there is no pressure fitting as in other types of connectors being used for single mode fibers which require much greater alignment tolerances. Below are some features of this connector:

- Threaded, no key (inconsistent mating)
- Non physical contact
- No spring mechanism
- Becoming Obsolete

### **ST Connector**

ST connectors replaced SMA connectors (See Figure 3). The ST (an AT&T Trademark) connector was one of the first connector types widely implemented in fiber optic networking applications. Originally developed by AT&T, it stands for Straight Tip connector. ST connections use a 2.5mm ferrule with a round plastic or metal body. The connector stays in place with a “twist-on/twist-off” bayonet-style mechanism. Although extremely popular for many years, the ST connector is slowly being supplanted by smaller, denser connections in many installations. ST is the most popular connector for multimode networks, like most buildings and campuses. It has a bayonet mount and a long cylindrical ferrule to hold the fiber. And because they are spring-loaded, you have to make sure that the fiber is seated properly. The ST is still the most popular multimode connector because it is cheap and easy to install.



**Figure 3. ST Connector**

- Entire Body Spring Loaded
- No Ferrule Isolation from connector body
- Bayonet Coupling

## ***Commercial Connectors Used in Spaceflight Applications***

**MIL-STD-38999/MIL-STD-29504**

The Earth Observer-1 (EO-1)<sup>1</sup> satellite which launched on November 21, 2000 was part of the New Millennium program. The EO-1 mission will develop and validate instruments and technologies for space-based Earth observations with unique spatial, spectral and temporal characteristics not previously available.

The "453" connector is Amphenol-Bendix's high reliability miniature circular connector made to the performance and dimensional specifications of MIL-C-38999 (See Figure 5), the military's specification for electrical, miniature, circular, connectors. **MIL-C-38999** electrical connectors were tested for their applicability to the on-orbit EVA satellite servicing environment. The investigation provided a methodical approach to the evaluation of the human-machine interface of these connectors. The physical characteristics of thirty-five **MIL-C-38999** connectors were tested in two simulated space environments, the NASA Johnson Space Center Weightless Environment Training Facility and an evacuated glovebox which incorporated the Extravehicular Maneuvering Unit series 3000 gloves. During the evacuated glovebox tests, the G&H 64600 Wing-Tab connector had the fastest operating time.<sup>2</sup>

Amphenol-Bendix's "453" was designed for NASA applications with "low outgassing" materials. The MIL-STD-1773 optical fiber based communication bus was qualified and successfully flown by NASA GSFC on the SAMPEX (Solar Anomalous Magnetospheric Particle Explorer) satellite launched on July 3, 1992. The success of SAMPEX led to acceptance of the MIL-STD-1773 data bus system in the XTE (X-ray Timing Experiment) satellite launched in on December 30, 1995 and on the TRMM (Tropical Rainfall Measuring Mission) November 27, 1997. Each of these later projects improved on the SAMPEX bus design by modifying various parts of the system hardware. With the exception of the "453" connector and the M29504 (See Figure 4) optical termini that is described here the basic passive optical components (the fiber, cable, star coupler **1**), have not changed.

### **XTE Cable Assemblies**

The Multimode cable assemblies used on XTE were fabricated at GSFC using Brand Rex cable with radiation-hard Corning fiber. The cables use 100/140 micron graded index of refraction fiber. They are terminated with physically contacting MIL-T-29504/4 (pin) or MIL-T-2904/5 (socket) fiber optic termini ( from Amphenol or non-contacting FSMA 905 fiber optic connectors from AMP Inc. The MIL-T-29504 termini are used on cable ends which interface with the star coupler or one of the PCA instruments. MIL-T-29504 Termini are installed in MIL-C-38999 series III connectors from Amphenol to form a complete multi-cable fiber optic connector. These miniature circular filter connectors are designed to combine the functions of a standard electrical connector and a feed-thru filter into one compact package.<sup>3</sup>

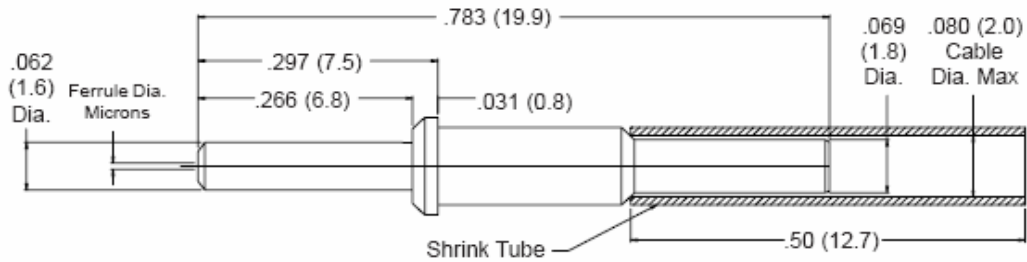

**Figure 4 MIL-T-29504 Termini**



**Figure 5. MIL-C-38999 Miniature Circular Filter Connectors**

## Johanson FC

The Johanson FC Connectors<sup>4</sup> were used on the Microwave Anisotropy Probe (MAP).<sup>5</sup> MAP was successfully launched on June 30, 2001 toward an orbit at the L2 libration point where it will investigate smaller scale variations in the cosmic microwave background radiation. The MAP mission will reveal conditions as they existed in the early universe by measuring the properties of the cosmic microwave background radiation over the full sky. This microwave radiation was released approximately 300,000 years after the birth of the universe. MAP will create a picture of the microwave radiation using temperature difference measured from opposite directions (anisotropy); the content of this image will tell us much about the fundamental structure of the universe.



**Figure 6 Johanson FC Connector**

- Keyed and threaded, consistent mating
- PC polish ferrule

- Spring Loaded Ferrules
- Pull proof (isolation of ferrule from body)

JPL Mars Science Lab<sup>6</sup> plans to include FC connectors into its fiber cabling design. FC/PC has been one of the most popular singlemode connectors for many years. It screws on firmly, but make sure you have the key aligned in the slot properly before tightening. It's being replaced by SCs and LCs.

## MTP

MTP® is a special type of fiber optic connector. Made by US Conec, it is an improvement of the original MPO (Multi-fiber Push-On) connector designed by NTT.



**Figure 7. MTP Connector**

The MTP® connector is designed to terminate several fibers—up to 12 strands—in a single ferrule. MTP® connections are held in place by a push-on/pull-off latch, and can also be distinguished by a pair of metal guide pins that protrude from the front of the connector. Because of the high number of fiber strands available in a small connection, MTP® assemblies are used for backbone, cross-connect, and break-out applications.

The EO-1 mission was launched on November 21, 2000. This mission was designed to develop and validate instruments and technologies for space-based Earth observations with unique spatial, spectral and temporal characteristics not previously available. A multi-fiber ribbon cable MTP connectorized assembly was slated to be space qualified for use on the Fiber Optic Data Bus (FODB) on the EO-1 Mission. Special 100/140 MTP connectors were ordered by the EO-1 mission. The Photonics Fiber Manufacturing lab began testing on the commercially available 62.5/125 MTP connectors which was funded by EO-1<sup>7</sup>. At the time the 100/140 MTP connectors arrived to be space qualified, the FODB was cancelled on the EO-1 mission. Fortunately the NASA Electronics Parts Program (NEPP) funded the NASA Photonics Laboratory to complete the space qualification of the 100/140 MTP connectors.<sup>8</sup> Because this qualification was funded by NEPP, the published results made available motivated Sandia National Laboratory to fund the NASA Photonics Laboratory to space qualify MTP connectors, with different vibration and thermal requirements, for a black box project that was being done at Sandia<sup>9</sup>.

## Diamond AVIMS



A trade study was conducted in 1994-1995 at Lockheed Martin<sup>10</sup> which was intended to identify space qualified or qualifiable fiber optic connectors for single mode fiber. The connectors had to be capable of an initial insertion loss of 0.5 dB maximum per mated pair, with an insertion loss of no more than 0.7 dB per mated pair after exposure to environments. After an exhaustive search, it was determined that there were no connectors supplied to existing American military specifications (MIL Specs) which were capable of meeting such requirements. As a result, the search was broadened to include commercially available connectors. A single-fiber connector candidate was identified, Diamond AVIMS (See Figure 8 and Figure 9), which utilizes an "active alignment" ferrule termination technique to achieve a typical insertion loss of 0.2 dB on single mode fiber. Subsequently, a multi-fiber connector candidate was identified for which the manufacturer was willing to produce termini substituting active alignment ferrules for the existing design standard ceramic ferrules.<sup>11, 12</sup>

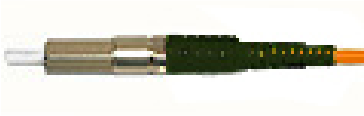

**Figure 8. Diamond AVIMS Connector**

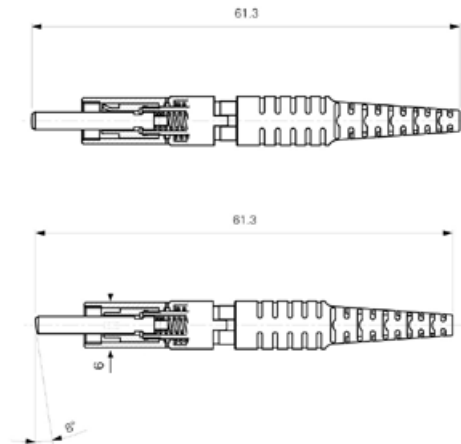

**Figure 9. Cross Section of Diamond AVIMS Connector**

The Geoscience Laser Altimeter System (GLAS) instrument which launched on January 12, 2003 was built to provide science data as part of ICESAT. The connectors and cable used for the GLAS assemblies were tested previously by Lockheed Martin in the mid 1990's. This data was accepted to prove that the Diamond AVIMS connectors themselves would function adequately for the duration of the mission.<sup>16</sup>

The Mercury Surface, Space Environment, Geochemistry and Ranging (MESSENGER) was launched on July 30, 2004. For the space flight mission MESSENGER, the Mercury Laser Altimeter (MLA) instrument required highly reliable optical fiber assemblies for the beam delivery system. A custom assembly was designed based on commercially available technologies to accommodate the requirements for the mission. These assemblies consisted of W.L.Gore FLEX-LITETM cable with 200 micron core

Polymicro Technologies optical fiber and the Diamond AVIMS connector kits. The assemblies were terminated to the NASA-STD-8739.5 in the Code 562 Advanced Photonics Interconnection Manufacturing Laboratory at NASA Goddard Space Flight Center. The technology validation methods that were used to characterize these assemblies for usage in a space flight environment have been established and well documented.<sup>15</sup>

JPL utilized ruggedized Diamond AVIMS<sup>13</sup> Connectors for the fiber cabling on the Tropospheric Emission Spectromoter (TES) which was launched on October 5, 2006. Over a five year period TES will gather data describing the global distribution of Tropospheric gases and other gas molecules that will be used to create a 3-D model depicting tropospheric chemistry.<sup>14</sup>

## REFERENCES

- 1 (NASA GSFC, p. Website describing Earth Observing 1 Mission
- 2 T. J. L. Griffin, Ruthan, Jan 1, 1989).
- 3 M. M. Jarosz, J. R. Kolasinski, and J. Croft, in *18th Annual AAS Guidance and Control Conference* (AAS Publication Office. , Keystone, Colorado, 1995).
- 4 J. Kolasinski, (NASA GSFC Greenbelt, MD, 1997), p. 6.
- 5 (NASA GSFC p. Website describing Microwave Anisotropy Probe
- 6 (NASA Jet Propulsion Laboratory (JPL).
- 7 M. N. Ott and J. W. Bretthauer, edited by W. T. Edward (SPIE, 1998), Vol. 3440, p. 57.
- 8 M. N. Ott, S. L. Macmurphy, and P. R. Friedberg, edited by D. Eric, J. H. Michael, R. P. Andrew and W. T. Edward (SPIE, 2002), Vol. 4732, p. 79.
- 9 X. Jin, M. N. Ott, F. V. LaRocca, R. M. Baker, B. E. N. Keeler, P. R. Friedberg, R. F. Chuska, M. C. Malenab, and S. L. Macmurphy, edited by W. T. Edward (SPIE, 2006), Vol. 6308, p. 63080T.
- 10 J. D. McFadden and J. McMurray, SPIE Photonics for Space Environments III **2482** (1995).
- 11 L. A. Reith, P. B. Grimado, R. A. Frantz, I. M. Plitz, W. W. Wood, and D. A. Dolinoy, SPIE **2811** (1994).
- 12 J. M. Lisa, edited by W. T. Edward (SPIE, 1996), Vol. 2811, p. 264.
- 13 M. L. C. Holdener, ([www.misspiggy.gsfc.nasa.gov/photonics](http://www.misspiggy.gsfc.nasa.gov/photonics), ESA-NASA Working Meeting on Optoelectronics: Fiber Optic Systems Technology in Space, 2005).
- 14 C. Asbury, ESA-NASA Working Meeting on Optoelectronics: Fiber Optic Systems Technology in Space, October 5, 2005).
- 15 Melanie. N Ott, P. Marcellus, D. Matthew, M. Shawn, and R. F. Patricia, edited by R. P. Andrew, W. T. Edward and J. H. Michael (SPIE, 2003), Vol. 5104, p. 96.
- 16 C. F. Mark, edited by B. Francis and W. T. Edward (SPIE, 2002), Vol. 4547, p. 86.
- 17 Technical Discussions with Melanie N. Ott, NASA GSFC.

