

**REVISIONS**

SYMBOL	DESCRIPTION	DATE	APPROVAL
--	INITIAL RELEASE	9-21-94	<i>[Signature]</i>

**SHEET REVISION STATUS**

SH	1	2	3	4	5	6	7	8	9	10	11	12	13	14	15	16	17	18	19	20
REV	--	--	--	--	--	--	--	--	--	--	--	--	--							
SH	21	22	23	24	25	26	27	28	29	30	31	32	33	34	35	36	37	38	39	40
REV																				
SH	41	42	43	44	45	46	47	48	49	50	51	52	53	54	55	56	57	58	59	60
REV																				

Originator M. J. Sampson /GSFC	<i>[Signature]</i>	DATE 09/21/94	FSC: 5910
Code 311 Approval /GSFC	<i>[Signature]</i>	9/21/94	Capacitor, Fixed, Axial-Lead, Metallized Polycarbonate Dielectric, Hermetically Sealed in Metal Cases. For use on the Hubble Space Telescope
Code 311 Supervisory Appl G. Kramer, Jr. /GSFC	<i>[Signature]</i>	9/21/94	
			S-311-P-785

NATIONAL AERONAUTICS AND SPACE ADMINISTRATION  
 GODDARD SPACE FLIGHT CENTER  
 GREENBELT, MARYLAND 20771

CAGE CODE: 25306

1. SCOPE

- 1.1 Scope. This specification covers the procurement requirements for fixed, metallized polycarbonate film dielectric, axial leaded capacitors, hermetically sealed in metal cases. These capacitors are only intended for use in the gyroscope circuits of the Hubble Space Telescope (HST).
- 1.2 Goddard part number. Parts procured in complete compliance with the requirements of this specification shall be identified by the following Goddard part number.

G311P785

- 1.3 Part ratings: The nominal capacitance, capacitance tolerance, rated voltage and dimensions shall be in accordance with the following:

Nominal capacitance:	8.2 $\mu$ F
Capacitance tolerance	$\pm 10\%$
Rated voltage:	50 vdc

Dimensions: In accordance with Figure 1

Figure 1

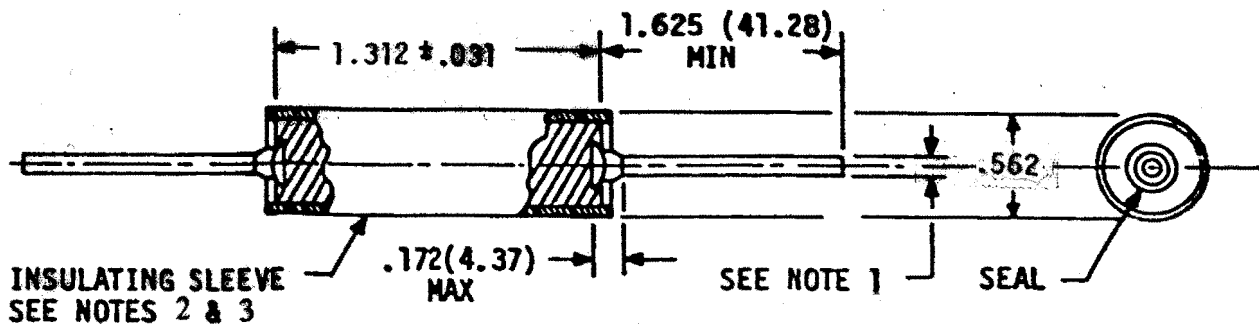

NOTES:

1. Terminal lead diameter and material shall be in accordance with paragraph 3.3.5.
2. Insulating sleeve shall extend beyond capacitor body but shall not exceed .031 inch (.79 mm) on either end. Insulating sleeve thickness shall not exceed .005 inch (.13 mm)
3. Plastic insulating sleeve shall be transparent; marking shall be applied to the capacitor case.
4. Case diameter tolerance is  $+.015, -.005$  inch and this dimension includes the insulating sleeve.
5. Dimensions are in inches.

## 2. APPLICABLE DOCUMENTS

- 2.1 Documents. The following documents, of the issue in effect on the date of invitation for bids or request for proposal, form a part of this specification to the extent specified herein.

### SPECIFICATIONS

MIL-C-39022	Capacitors, Fixed, Metallized, Paper-Plastic Film Dielectric, Direct Current, (Hermetically Sealed in Metal Cases), Established Reliability, General Specification for
MIL-C-39022/10	Capacitors, Fixed, Metallized, Paper-Plastic Film Dielectric, Direct Current, (Hermetically Sealed in Metal Cases), Established Reliability. Style CHR10 (Insulated)
MIL-C-83421	Capacitors, Fixed, Metallized Plastic Film Dielectric, (DC, AC, or DC and AC), Hermetically Sealed in Metal or Ceramic Cases, Established Reliability, General Specification for
MIL-C-83421/1	Capacitors, Fixed, Metallized Plastic Film Dielectric, DC and AC, Hermetically Sealed in Metal Cases, Established Reliability. Style CRH01
MIL-C-87217	Capacitors, Fixed, Supermetallized Plastic Film Dielectric, Direct Current for Low Energy, High Impedance Applications, Hermetically Sealed in Metal Cases, High Reliability, General Specification for
MIL-I-45208	Inspection Systems Requirements
MIL-C-39028	Capacitors, Packaging of
QQ-S-571	Solder; Tin Alloy; Tin-Lead Alloy; and Lead Alloy

### STANDARDS

MIL-STD-202	Test Methods for Electronic and Electrical Component Parts
MIL-STD-1276	Leads for Electronic Component Parts
MIL-STD-1285	Marking of Electrical and Electronic Parts

2.2 Order of precedence. In the event of any conflict between the text of this specification and the references cited herein, the text of this specification shall take precedence. However, nothing in this text shall supersede applicable laws and regulations unless a specific exemption has been obtained.

2.3 Copies of documents. Copies of federal and military documents can be obtained from the Standardization Document Order Desk, 700 Robbins Avenue, Building #4-Section D, Philadelphia, PA 19111-5094.

### 3. REQUIREMENTS

3.1 Qualification. Capacitors furnished to this specification shall be products that have been granted qualification approval by NASA/GSFC. Qualification approval shall be based on the following criteria.

3.1.1 Design and source approval. Prior to qualification, the manufacturer's facility shall be subjected to survey at the option of GSFC, by the Office of Flight Assurance, GSFC. Compliance with MIL-I-45208 and a current qualification to the R failure rate (0.01%/1000 hrs) for MIL-C-83421/1, are required. In addition, the history and detailed engineering of the specific capacitor design will be reviewed, as will the documented manufacturing and quality control procedures. Only those sources approved in the design and source approval phase shall be eligible for qualification or award of contract under this specification. Source approval and design approval do not constitute part qualification or an equivalent thereof.

3.1.2 Part qualification. Qualification inspection is not required. Only capacitors manufactured by a source currently qualified to at least the R established failure rate level (0.01% / 1000 hrs) for MIL-C-83421/1, can be granted qualification to this specification.

3.2 Materials. Materials shall be as specified herein. However when a definite material is not specified, a material shall be used which will enable the capacitors to meet the performance requirement of this specification. Acceptance of any constituent material shall not be construed as a guaranty of the acceptance of finished product. Unless stated otherwise, the materials shall be in accordance with of MIL-C-39022/10.

3.3 Design and construction. Capacitors shall be of the design, construction and dimensions depicted in Figure 1. Unless stated otherwise, the general design and construction requirements shall be in accordance with MIL-C-39022/10.

3.3.1 Dielectric. Metallized polycarbonate film.

- 3.3.2 Capacitor element (winding). The maximum practical film thickness shall be used. Creases or wrinkles in the film shall be minimized. The element shall be wound using double burn-off isolation at both start and finish. Double burn off is defined as the removal of the metallized electrode layer from both dielectric films for sufficient length to provide voltage isolation and a heat sealable area if applicable. The core area shall be reinforced; heat sealing of the start turns is preferred.
- 3.3.3 Case. Capacitors shall be enclosed in hermetically-sealed, corrosion resistant, metal cases. The cases shall be constructed so that they are insulated from both terminal leads in accordance with Circuit Diagram 1 of MIL-C-39022/10. The end seals shall be glass-to-metal seals.
- 3.3.4 Insulation. Capacitor cases shall be insulated in accordance with the requirements of MIL-C-83421/1.
- 3.3.5 Terminal leads. Axial-wire terminal leads shall consist of solder coated, oxygen free number 20 AWG (0.032" diameter) copper clad steel conductors, to the requirements of MIL-STD-1276E, types W-45 or W-52 and meet the solderability requirement (see 4.6.10).
- 3.3.6 Internal construction. The capacitor element shall be supported in the case so that the finished capacitor meets the 50g sinusoidal vibration requirement of MIL-C-83421/1 (MIL-STD-202, method 204, condition E, for 4 hours in each of two mutually perpendicular axes). The winding shall be wrapped with tape, encapsulated, or otherwise packed, to build up its diameter so that it is a tight fit in the case.
- 3.3.7 Operating temperature range. Capacitors shall be capable of operating for extended periods at -65°C to +100°C at full rated voltage; or with the voltage derated linearly, from full rated at 100°C to 50% of rated at 125°C.
- 3.4 Burn-in. When tested as specified in 4.6.2, capacitors shall withstand the exposure to high temperature and overvoltage without visible damage.
- 3.5 Thermal shock. When tested as specified in 4.6.3, capacitors shall withstand the extremes of low and high temperature without visible damage.
- 3.6 Seal. When tested as specified in 4.6.4, there shall be no repetitive bubbling for the gross leak test and the fine leak rate shall be less than  $1 \times 10^{-6}$  atm. cc./sec..
- 3.7 Dielectric withstanding voltage. When tested as specified in 4.6.5 capacitors shall be capable of withstanding the required potential for the time specified without permanent damage, or open- or short-circuiting

3.8 Insulation resistance. When tested as specified in 4.6.6, the insulation resistance shall meet the following:

Terminals to case:	10,000 megohms minimum
Terminal to terminal at 25°C:	12,200 megohms minimum
Terminal to terminal at 100°C:	1,200 megohms minimum

3.9 Capacitance and tolerance. When tested as specified in 4.6.7, the capacitance value shall be between 7.38  $\mu\text{F}$  minimum and 9.02  $\mu\text{F}$  maximum.

3.10 Dissipation factor. When tested as specified in 4.6.8, the dissipation factor shall not exceed 0.15 percent.

3.11 Radiographic inspection. When radiographed in accordance with 4.6.9, the capacitors shall meet the requirements of MIL-C-87217 Appendix B except as modified herein.

3.12 Solderability. When tested as specified in 4.6.10 the dipped portion of the terminal leads of the capacitors shall conform to the solid-wire termination criteria of method 208 of MIL-STD-202. One lead on a capacitor which fails to meet these criteria shall constitute a failure.

3.13 Life. When tested as specified in 4.6.11, capacitors shall meet the following requirements:

Insulation resistance:

Terminal to terminal (25°C):	4,100 megohms, minimum
Terminal to terminal (100°C):	400 megohms, minimum
Terminal to case:	10,000 megohms, minimum

Capacitance change:  $\pm 2.0$  percent maximum

Dissipation factor: 0.25 percent maximum

3.14 Marking. Each capacitor shall be marked with the Goddard part number, source code, manufacturer's name or symbol (optional), capacitance value and tolerance, rated voltage, and date code. In addition each capacitor shall be marked with a unique serial number; adhesive serial number labels shall not be used. Date and source code shall be in accordance with MIL-STD-1285. The location and number of lines and inclusion of additional information, are at the manufacturer's discretion.

The following is an example of the basic marking requirement:

XYZ ----- Manufacturer's name or symbol (optional)  
12345 ----- Manufacturer's source code (CAGE)  
G311P785 ----- Goddard part number  
8.2  $\mu$ F  $\pm$  10% ----- Capacitance value and tolerance  
50V 94XXA ----- Rated voltage and lot date code (including sub lot identifier)

3.14.1 Date code. The date code shall show the date of the final assembly operation for the production lot. Individual production lots finished in the same week may be combined into one inspection lot under the same four digit date code but additional character(s) or the serial number shall be used to provide traceability to the production sub lots.

3.15 Workmanship. Capacitors shall be processed in such a manner as to be uniform in quality and, when inspected in accordance with 4.6.1, shall be free from pits, corrosion, cracks, rough edges and other defects that will affect life or serviceability.

#### 4. QUALITY ASSURANCE PROVISIONS

4.1 Responsibility for inspection. The manufacturer is responsible for the performance of all inspection requirements, as specified herein, using his own or any other suitable facility acceptable to Goddard Space Flight Center. Upon receipt of product, Goddard reserves the right to perform any of the inspections set forth in the specification where such inspections are deemed necessary to verify conformance to prescribed requirements.

4.2 Classification of inspection. Inspection requirements specified herein are classified as follows:

- a. Qualification Inspection (see 4.4)
- b. Quality Conformance Inspection (see 4.5)

4.3 Inspection conditions. Unless otherwise specified herein, all inspections shall be performed in accordance with the test conditions specified in the "GENERAL REQUIREMENTS" of MIL-STD-202.

4.4 Qualification inspection. Qualification inspection is not required. However the manufacturer of these capacitors must be currently qualified to at least the R failure rate level for MIL-C-83421/1.

4.5 Quality conformance inspection. Quality Conformance Inspection (QCI) shall be performed on all product furnished to this specification.

- 4.5.1 Inspection of product for delivery. Inspection of product for delivery shall consist of Group A inspection per Table I. Group B testing per Table II, need not be completed prior to shipment. However, final lot acceptance by GSFC is dependent upon successful completion of Group B testing.
- 4.5.2 Inspection lot. An inspection lot shall consist of all capacitors presented for inspection to this specification during the same week, using the same processes and identified by the same lot date code.
- 4.5.3 Group A inspection. Group A inspection shall consist of the examinations and tests specified in Table I and shall be performed in the order shown.
- 4.5.3.1 Subgroup 1 tests. Subgroup 1 tests shall be performed on 100 percent of the capacitors supplied under this specification. Capacitors which fail to meet any of the test requirements under paragraph 3 shall be removed from the inspection lot. Only lots having not more than 5 percent total catastrophic rejects, or one catastrophic reject capacitor, whichever is greater, shall be supplied to this specification. For this determination, a catastrophic reject is defined as a capacitance value more than 20% above or below the nominal value, a dielectric withstanding voltage failure, an insulation resistance of less than 100 megohms, or a dissipation factor greater than 0.25%.
- 4.5.3.2 Subgroup 2 and 3 tests. Subgroup 2 and 3 inspections shall be performed on capacitors passing subgroup 1 inspections. The number of samples inspected shall be as specified in Table I. In the event the number of failures exceeds the accept number in Table I, the lot shall be rejected.
- 4.5.3.3 Lot rejections. Rejected lots shall be segregated from new lots and those lots passing the subgroup 2 and subgroup 3 inspections. Lots rejected in subgroup 2 shall be 100 percent inspected for those quality characteristics found defective in the sample, and any defects found shall be removed from the lot. After reinspection, another random sample of the size specified in Table I shall be selected. In the event one or more failures are found in this second sample, the lot shall be rejected and shall not be supplied to this specification. Lots rejected in subgroup 3 may be reworked using a MIL approved solder dipping (retinning) process, two times only. Following the solder dip, the electrical measurements and tests required in group A subgroup 1 including seal and radiographic inspection shall be repeated on 100 percent of the lot. The PDA for the electrical measurements shall be as for subgroup 1 tests. Three additional samples shall then be selected and subjected to the solderability test with zero rejects allowed. If the sample fails following the first rework, a second retinning is permitted. If the lot fails after it has been reworked twice, the lot shall be rejected and shall not be supplied to this specification..



TABLE I. Group A inspection.

Inspection	Requirement paragraph	Test method paragraph	Sample size	Lot acceptance criteria, A/R
<u>Subgroup 1</u>				
Burn-in - - - - -	3.4	4.6.2	100%	
Thermal shock - - - - -	3.5	4.6.3	100%	
Seal - - - - -	3.6	4.6.4	100%	
Dielectric withstanding voltage	3.7	4.6.5	100%	P.D.A
Insulation resistance <u>1/</u> - - - - -	3.8	4.6.6	100%	P.D.A
Capacitance - - - - -	3.9	4.6.7	100%	P.D.A
Dissipation factor - - - - -	3.10	4.6.8	100%	P.D.A
Radiographic inspection <u>2/</u> - -	3.11	4.6.9	100%	
<u>Subgroup 2</u>				
Visual and mechanical - - - - -	Various	4.6.1	13	0/1
<u>Subgroup 3</u>				
Solderability <u>3/</u> - - - - -	3.12	4.6.10	3	0/1

1/ Measurements are required at 25°C and 100°C.

2/ May be performed anywhere in the Group A sequence, following thermal shock.

3/ Test may be performed on electrical rejects.

4.5.4 Group B inspection. Group B inspection shall consist of the tests specified in Table II and shall be performed in the order shown.

4.5.4.1 Sample size. A random sample, of the size specified in Table II, shall be selected. If the number of rejected parts exceeds the accept quantity shown in Table II, GSFC shall be informed within two working days of the discovery of the lot failure. Final lot disposition will be by GSFC.

4.5.4.2 Disposition of sample units. Sample units which have been subjected to Group B inspection shall be placed in a package clearly identified "Group B sample parts" and shipped to GSFC.

4.5.4.3 Disposition of failed units. Sample units which fail Group B testing shall be clearly labelled as "Group B failures" and shipped to GSFC for analysis.

TABLE II. Group B inspection.

Inspection	Requirement paragraph	Test method paragraph	Sample size	Lot acceptance criteria, A/R
Life - - - - -	3.13	4.6.11	50	1/2

4.5.5 Inspection records. The manufacturer shall compile a record of all QCI inspection results. As a minimum this record shall include a summary of Group A test results, and Group B variables data by capacitor serial number. The Group A summary shall be shipped with the order. The Group B variables data shall be shipped with the Group B samples, after the completion of Group B.

4.5.6 Retention of qualification. Retention of qualification to this specification requires that the manufacturer continues to meet the requirements of paragraph 3.1. In addition follow up facility audits may be required.

4.6 Methods of inspection.

4.6.1 Visual and mechanical inspection (see 3.2, 3.3, 3.3.3, 3.3.4, 3.3.5, 3.14 and 3.15). Capacitors shall be examined to verify that materials, design, construction, physical dimensions, marking and workmanship are in accordance with the applicable requirements.

4.6.2 Burn - in (see 3.4). Capacitors shall be tested under the following conditions:

- a. Temperature: 125°C, +4°C, -0°C
- b. Voltage: 35 vdc
- c. Duration: 96 hours minimum

4.6.3 Thermal shock (see 3.5). Capacitors shall be tested in accordance with method 107 of MIL-STD-202. The following details and exceptions shall apply:

- a. Test condition letter B
- b. Measurements before and after test are not applicable
- c. 10 cycles

4.6.4 Seal (see 3.6). Capacitors shall be tested in accordance with method 112 of MIL-STD-202. The following details shall apply:

- a. Fine leak test: Condition C, except helium exposure shall be at  $45 \pm 5$  lbf/in<sup>2</sup> for 1.0, +1.0, -0 hours and the dwell between exposure and leak rate determination shall not exceed 1.0 hour.

- b. Gross leak test: Condition A, or alternate condition D.
- c. Measurements after test are not applicable.

4.6.5 Dielectric withstanding voltage (see 3.7). Capacitors shall be subjected to this test, performed both terminal-to-terminal and terminal-to-case.

4.6.5.1 Terminal-to-terminal, dc test. Capacitors shall be tested in accordance with the requirements of MIL-C-83421/1 and method 301 of MIL-STD-202. The following details and exceptions shall apply.

- a. Magnitude of test voltage: 85 vdc,  $\pm 2\%$
- b. Points of application of test voltage: between terminals
- c. Current resistor: sufficient to limit charging current to 1.0 ampere max.
- d. Electrification time: 60 seconds minimum.

4.6.5.2 Terminal-to-terminal, ac test. Capacitors shall be tested in accordance with the requirements of MIL-C-83421/1 and method 301 of MIL-STD-202. The following details and exceptions shall apply.

- a. Magnitude of test voltage: 90 volts peak-to-peak,  $\pm 2\%$
- b. Frequency of test voltage:  $100 \pm 10$  Hz
- c. Waveform of test voltage: in accordance with MIL-C-83421/1
- d. Points of application of test voltage: between terminals
- e. Electrification time: 60 seconds minimum.

4.6.5.3 Terminal-to case test. Capacitors shall be tested in accordance with the requirements of MIL-C-83421/1 and method 301 of MIL-STD-202. The following details and exceptions shall apply.

- a. Magnitude of test voltage: 85 to 100 vdc
- b. Points of application of test voltage: between terminals shorted together and the case
- c. Current resistor: sufficient to limit charging current to 1.0 ampere max.
- d. Electrification time: 60 seconds minimum.

4.6.6 Insulation resistance (see 3.8). Capacitors shall be tested in accordance with method 302 of MIL-STD-202. The capacitors shall be measured at rated voltage (50 vdc), both between terminals and between terminals and case. Terminal to terminal measurements shall be made at  $25^{\circ}\text{C} \pm 3^{\circ}\text{C}$  and also at  $100^{\circ}\text{C} \pm 4^{\circ}\text{C}$ , when specified. During this test, the capacitors shall be electrified for a maximum of 12 minutes, including read time.

4.6.7 Capacitance (see 3.9). Capacitors shall be tested in accordance with method 305 of MIL-STD-202. The measurement frequency shall be  $1,000 \pm 100$  Hz at an accuracy of  $\pm 0.05\%$ .

4.6.8 Dissipation factor (see 3.10). Dissipation factor shall be measured at a frequency of  $100 \pm 10$  Hz.

4.6.9 Radiographic inspection (see 3.11). Capacitors shall be radiographed in accordance with Appendix B of MIL-C-87217. The following details shall apply:

- a. Two views perpendicular to the plane of the leads, with the second view made after the rotation of each capacitor by  $90^\circ$  around its own axis.
- b. The films shall be inspected on a backlighted illuminator using a minimum of 10X magnification.
- c. Capacitors containing any defects as specified in MIL-C-87217, appendix B, figure 3 shall be rejected, except extraneous particles up to 0.03 inch (0.76 mm) in their maximum dimension shall not be cause for rejection.
- d. A summary of the results of radiographic inspection shall be included in the report of Group A inspection furnished with each shipment of capacitors. The summary shall include, the number of parts inspected, accepted, and rejected, and the causes for rejection.
- e. Copies of the corresponding radiographic films and test reports shall be furnished with parts supplied to this specification.

4.6.10 Solderability (see 3.12). Capacitors shall be tested in accordance with method 208 of MIL-STD-202 and MIL-C-83421/1. This test is considered destructive.

4.6.11 Life (see 3.13). Capacitors shall be tested in accordance with method 108 of MIL-STD-202 and MIL-C-83421/1. The following details and exceptions shall apply:

- a. Test temperature:  $100^\circ\text{C}$ ,  $+4^\circ\text{C}$ ,  $-0^\circ\text{C}$
- b. Test voltage: 70 vdc (140% of rated)
- c. Test duration: 1,200 hours minimum, with intermediate measurements required after 500 hours
- d. Measurements during test: Not applicable
- e. Initial, intermediate and final measurements: If necessary, capacitors shall be returned to the conditions specified in 4.3. The insulation resistance, capacitance and dissipation factor shall be measured as specified in 4.6.6, 4.6.7 and 4.6.8. respectively. Insulation resistance measurement at  $100^\circ\text{C}$  is required for initial and final measurements only.
- f. Inspections after test: Capacitors shall be visually inspected for evidence of corrosion or mechanical damage.

5. **PACKAGING, SAMPLES AND DATA SUBMISSION**

5.1 **Packaging requirements.** The requirements for packaging shall be in accordance with MIL-C-39028.

5.2 **Sample and data submissions.** The following samples and data shall be submitted as required to the custodian at the address given in 6.3:

- a. Radiographic films (4.6.9) and Group A summary data (4.5.5) shall be supplied with the order.
- b. Group B test samples (4.5.4) and variables data (4.5.5) shall be supplied after the completion of Group B testing.

6. **NOTES**

6.1 **Ordering data.** Acquisition documents should specify the following:

- a. Number, title, and date of this specification.
- b. Goddard Part Number.
- c. Quantity.

6.2 **Qualification provisions.** With respect to product requiring qualification, awards will be made only for product which has been tested and approved by GSFC before the time for opening of bids. The attention of the suppliers is called to the following requirement: manufacturers should arrange to have qualification tests made on product which they propose to offer to GSFC to become eligible for awards of contracts or orders for product covered by this specification. The manufacturer shall bear the cost of qualification inspection to this specification. Information pertaining to qualification of product may be obtained from the activity whose address is listed in 6.3.

6.3 **NOTICE.** When GSFC drawings, specifications, or other data are sent for any purpose other than in connection with a definitely related GSFC procurement operation, the United States Government thereby incurs no responsibility nor any obligation whatsoever. The fact that GSFC might have formulated, furnished or in any way supplied the said drawings, specifications, or other data is not to be regarded by implication or otherwise as in any manner licensing the holder or any person or corporation, or conveying any right or permission to manufacture, use, or sell any patented invention that may in any way be related thereto.

Custodian:

Code 311.2  
Goddard Space Flight Center  
Greenbelt, MD 20771