



Status and Update of 3D Heterogenous Integration Technology

June 13, 2023

Robert Patti

rpatti@NHanced-semi.com

630-561-6813



Effective End of Moore's Law

Moore's Law was first and foremost a statement about economics. We could shrink transistors and build more of them for about the same cost.

- This has been the basic premise of the semiconductor industry for 50 years and was true up until the last few years.
- Today we can indeed shrink transistors further, but the cost per transistor no longer declines.

We can get something a little more compact

- Perhaps a little less power
- But we pay more for these features now.



What Does This Mean?

The semiconductor industry is about to undergo a sea change.

- New ways of accomplishing Moore's law economics and performance are needed.
 - The industry is now looking to use advanced packaging to drive future semiconductors.
 - Better Cost
 - Better Performance
 - Better SWaP



Vision of the Future

A new semiconductor industry paradigm is evolving...

Foundry 2.0 –

A Finishing Foundry that takes the standardized building blocks from traditional semiconductor manufacturers and uses advanced packaging and additive manufacturing to create highly customized components with superior performance targeting small and medium sized markets.

What Is Advanced Packaging?

- Sensors (Cameras)
 - Sony 10+ years ago, - now mainstream
 - Virtually every new USG IR sensor is an AP
 - Driven by size/form factor
 - System cost reduction
- GPUs
 - Dawn of both interposers and chiplets
- Micro-Displays
 - Driven by materials (GaN) and pitch requirements
- Compute Devices
 - leading edge risk takers
 - AMD and Xilinx early and now Intel
 - Driven by
 - Memory BW/Latency
 - Heterogenous targeted compute
 - Photonics coming on scene for I/O and compute
 - Lower power per bit-op
 - Effective Larger die with much better yield/cost

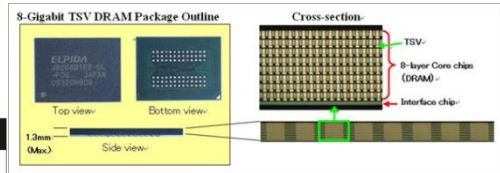
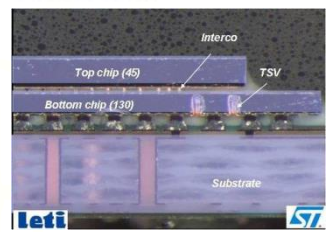
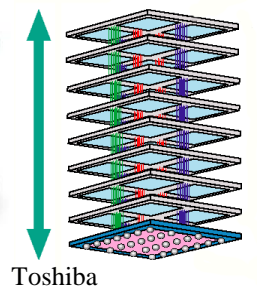
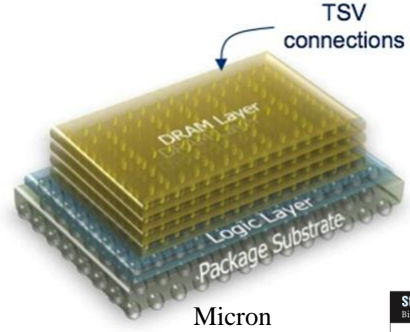
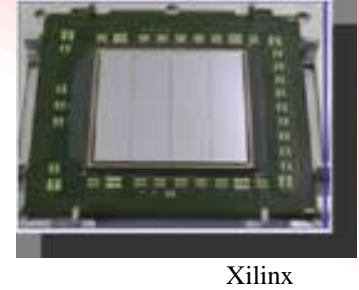
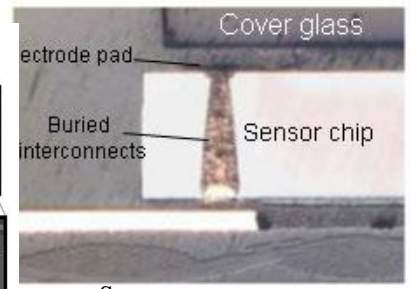
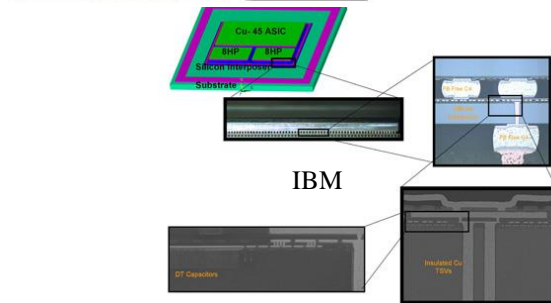
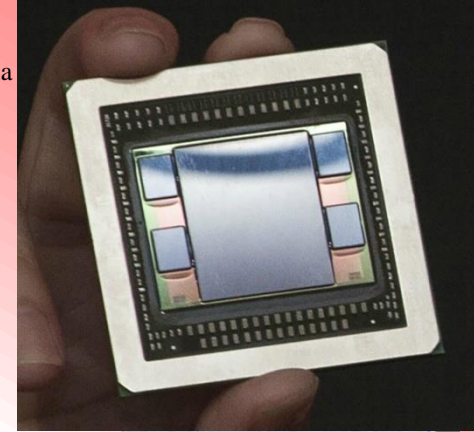
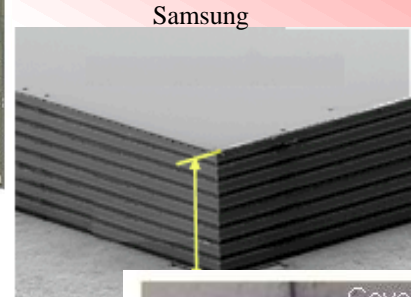
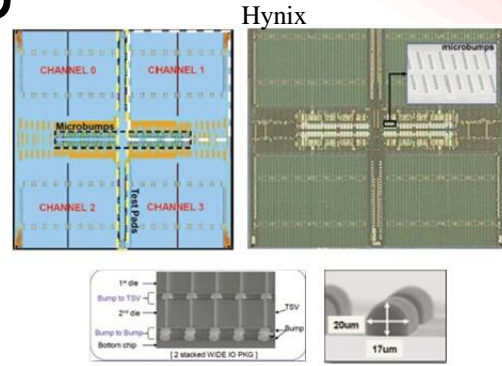

AP Elements: Bonding

Millimeters \rightarrow Microns

Kilograms \rightarrow Grams

Mixed Materials
Best of Class

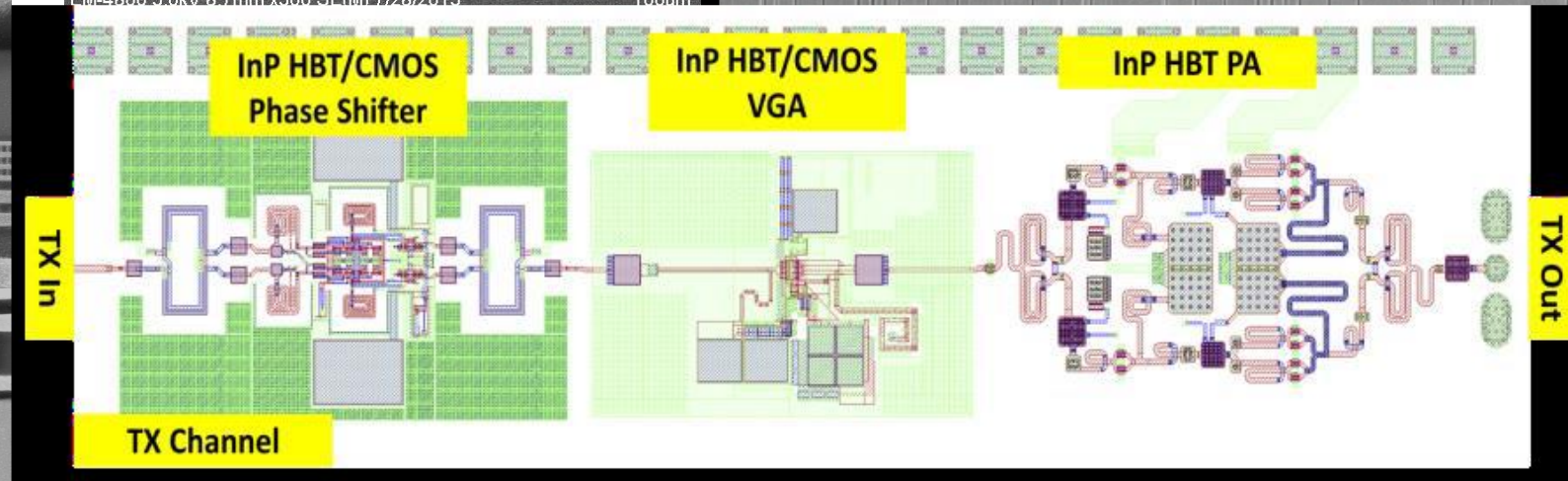
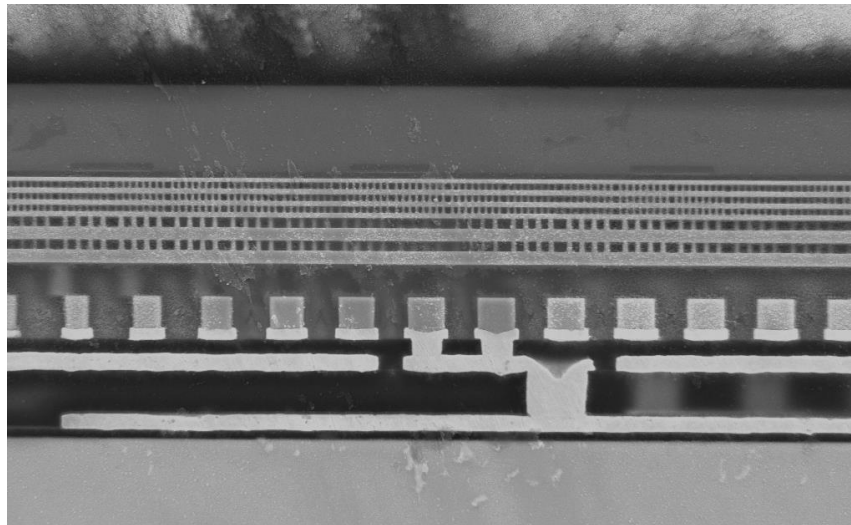
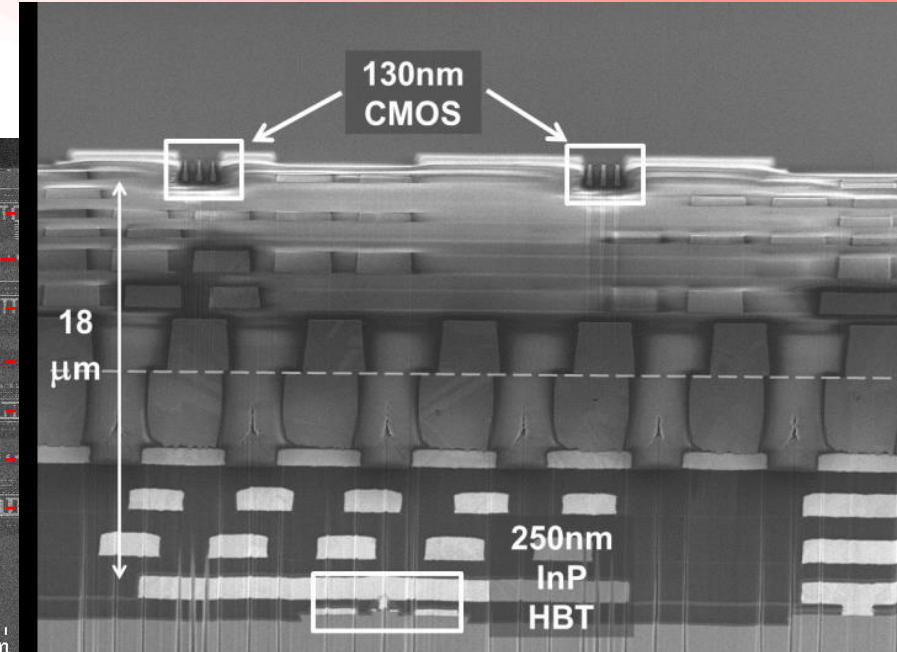
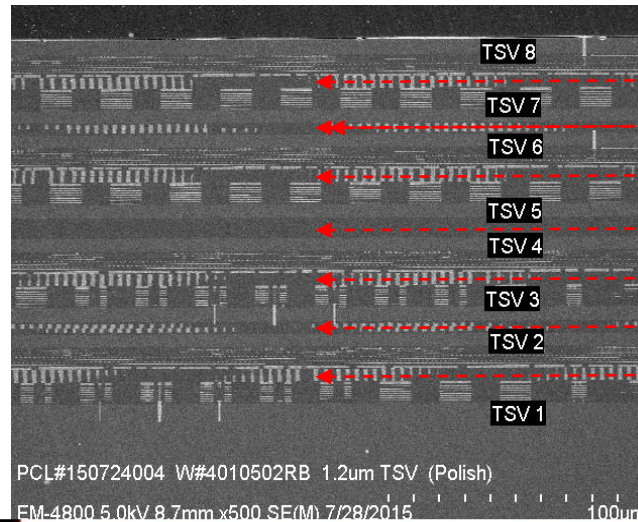

DBI[®]: Low Temperature Hybrid Bonding Process

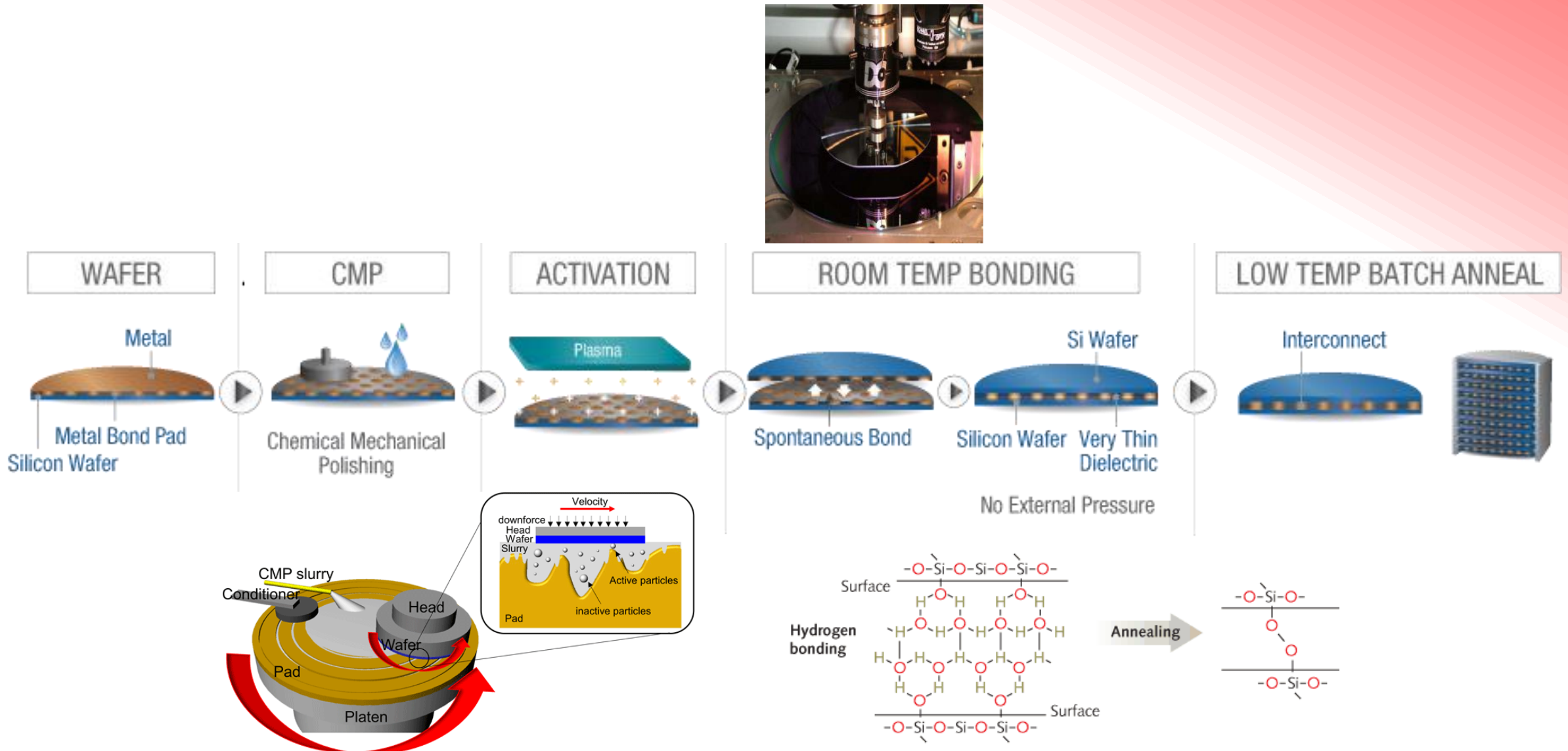

Hybrid Bonding Interconnect Pitch Scaling

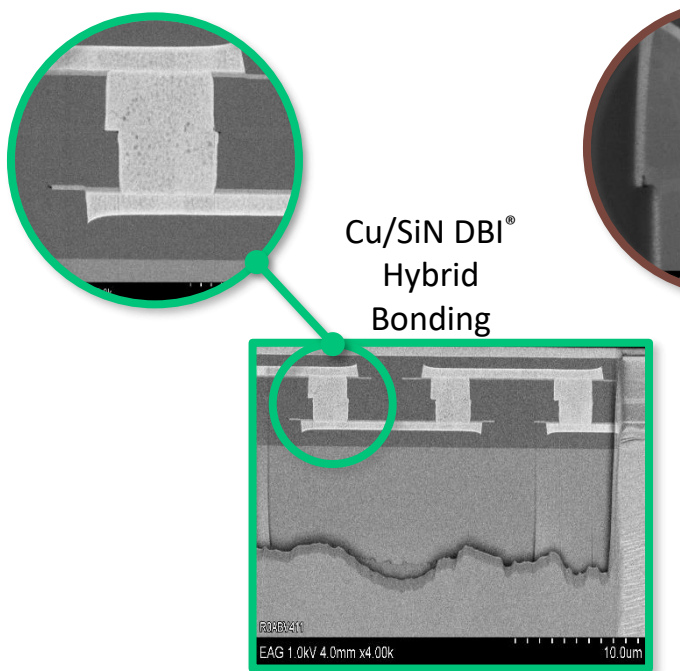

Cu/SiN DBI[®]
Hybrid
Bonding

10 µm DBI[®] pitch, 300°C

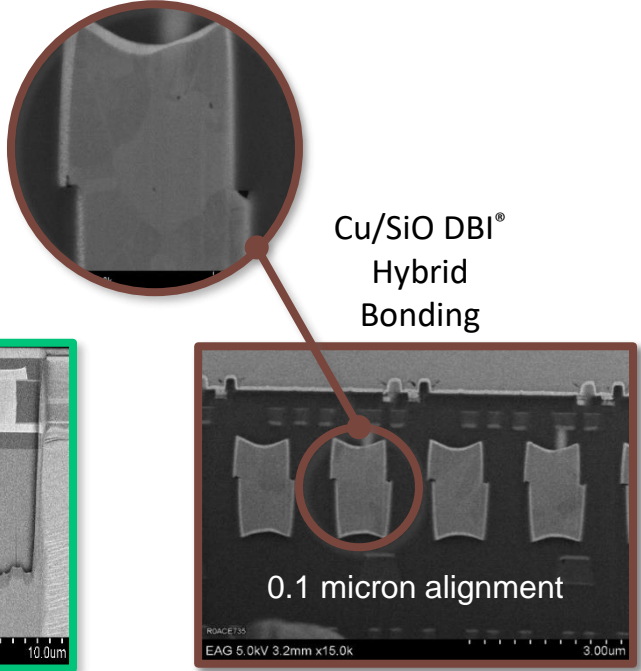

Cu/SiO DBI[®]
Hybrid
Bonding

1.9 µm DBI[®] pitch, 300°C

Scalable To < 1µm Pitch

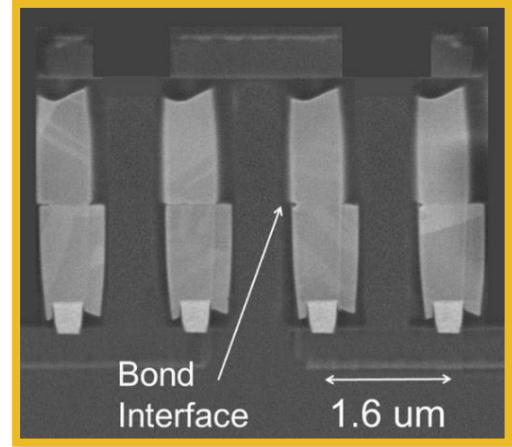

1.6 µm DBI[®] pitch,
300°C

- 3sigma < +/- 1µm misalign performance
- Production Minimum pitch = 2.44µm
- Best alignment is achieved with face-to-face bonding

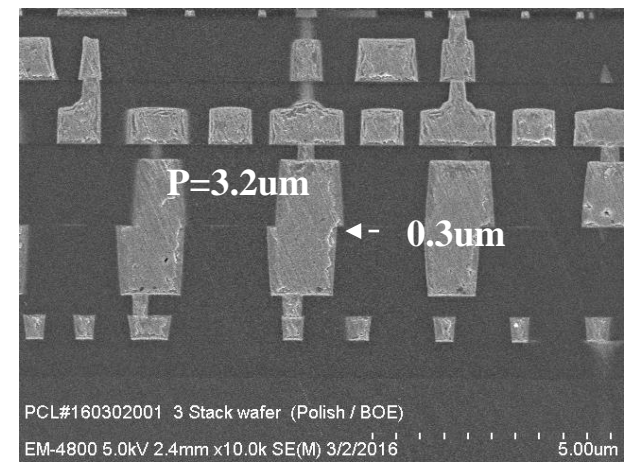
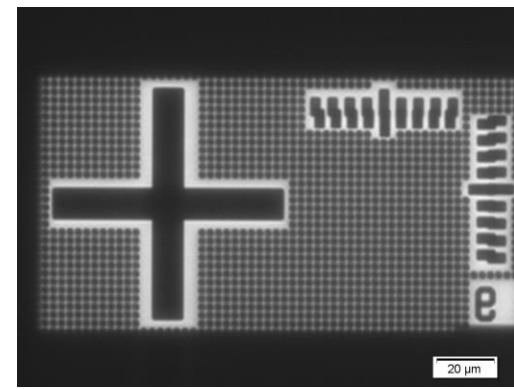

AP Elements: Interposers

- Bigger, Better, Faster
- Lower Power

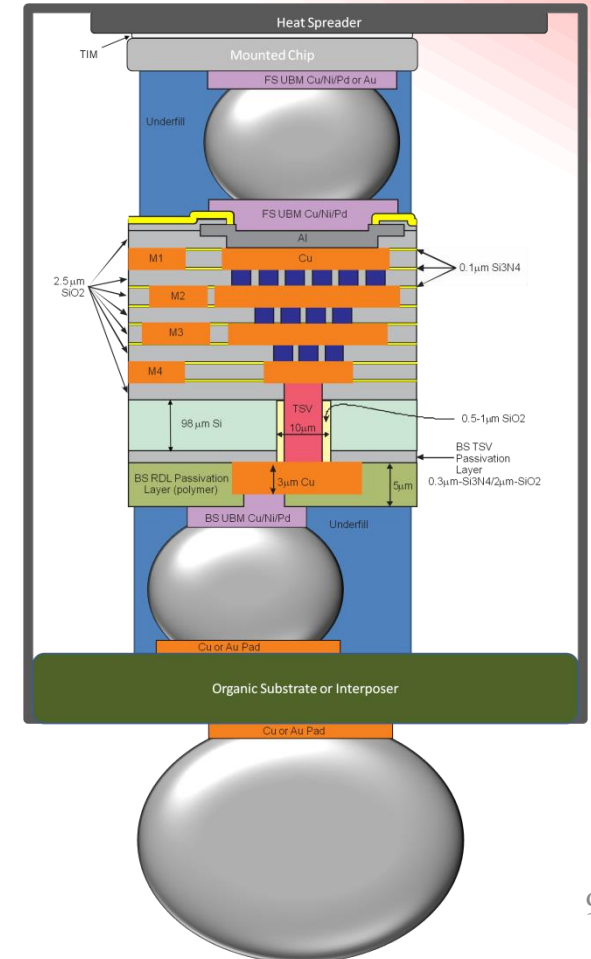
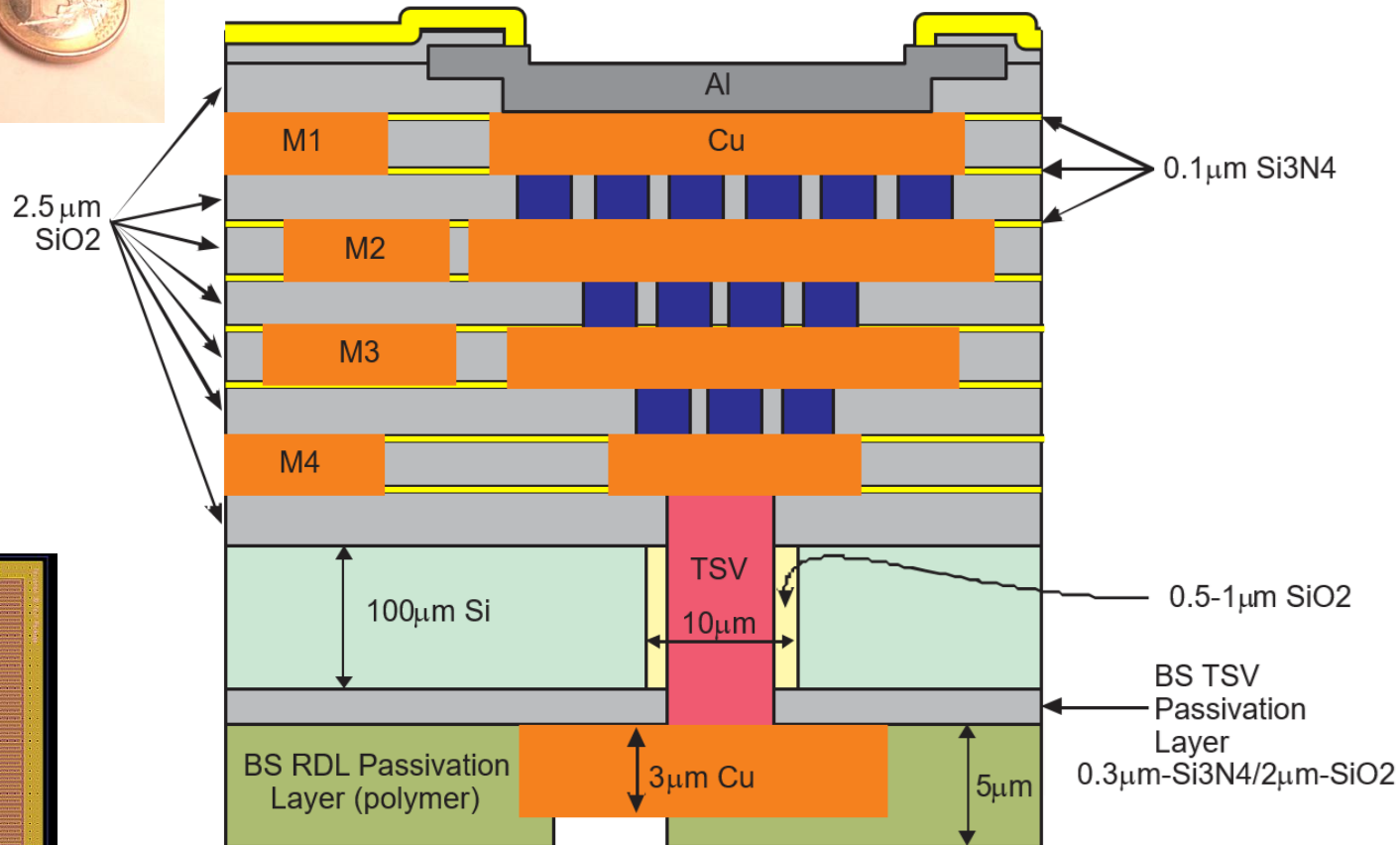
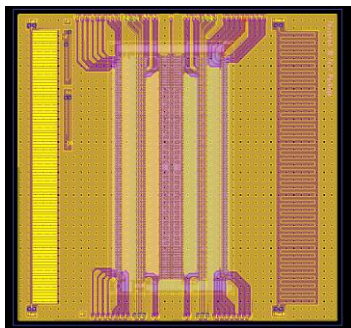
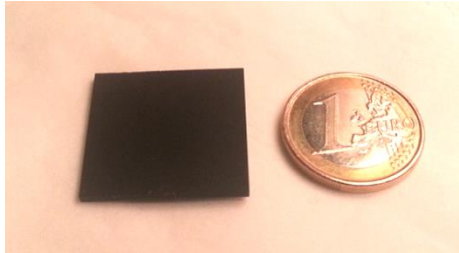
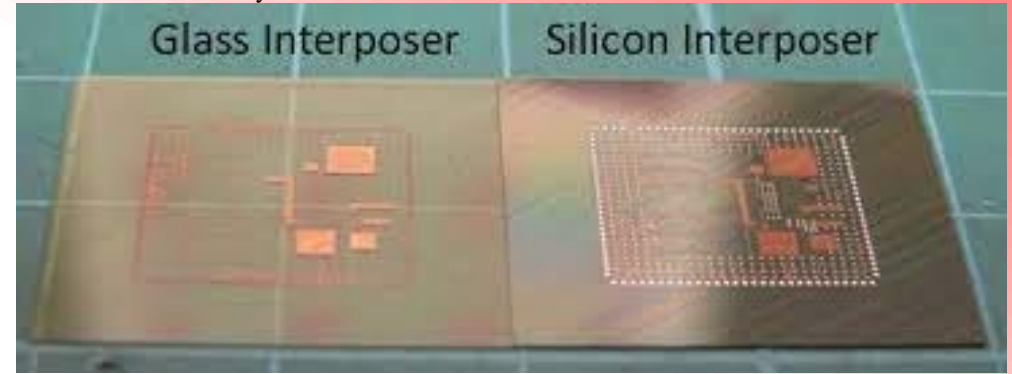

AP Elements: Wiring (Metallization)

- Wire length controls the delay
 - Span of control
- Accounts for majority of power usage
 - Memory fetch

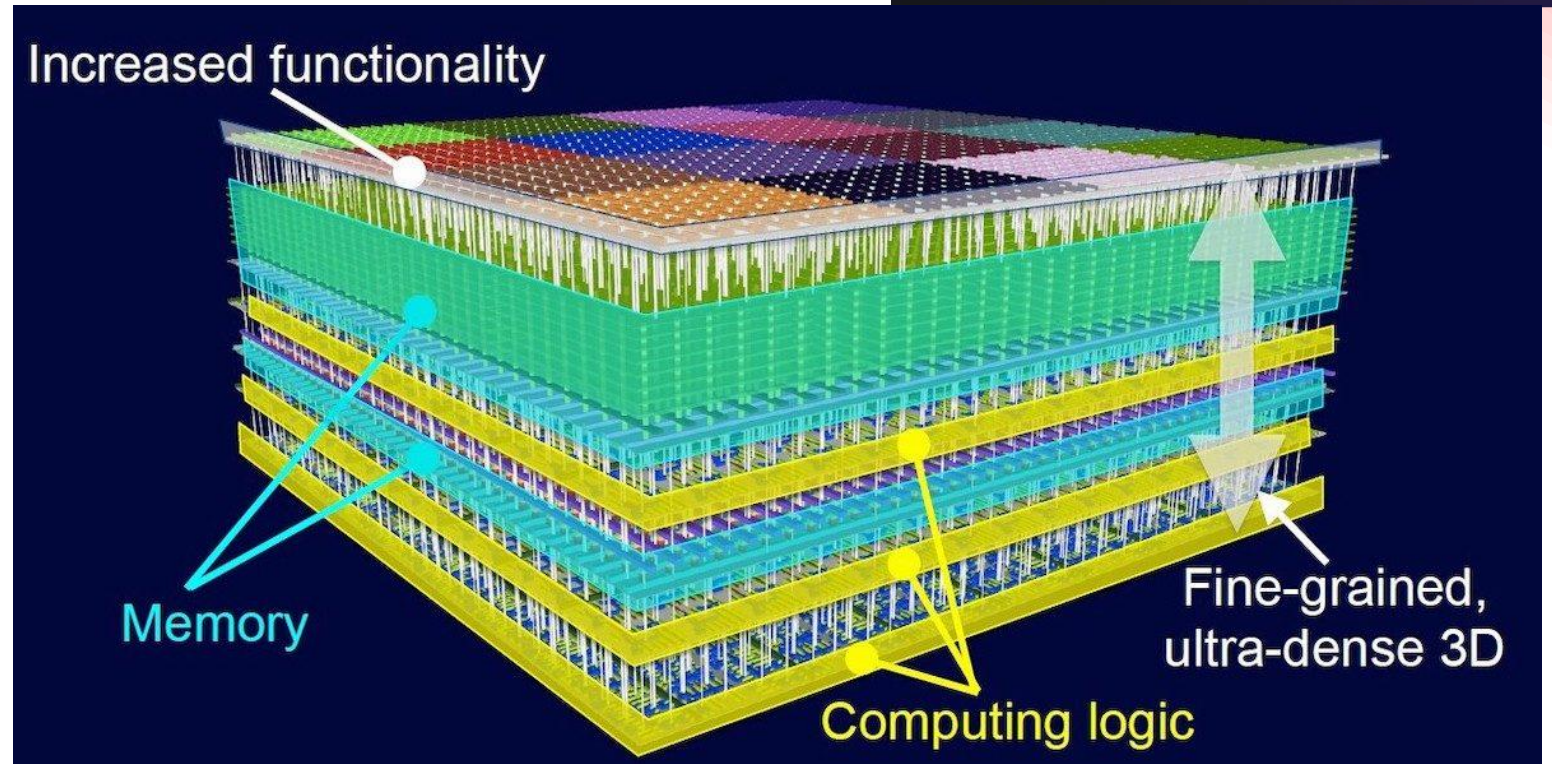
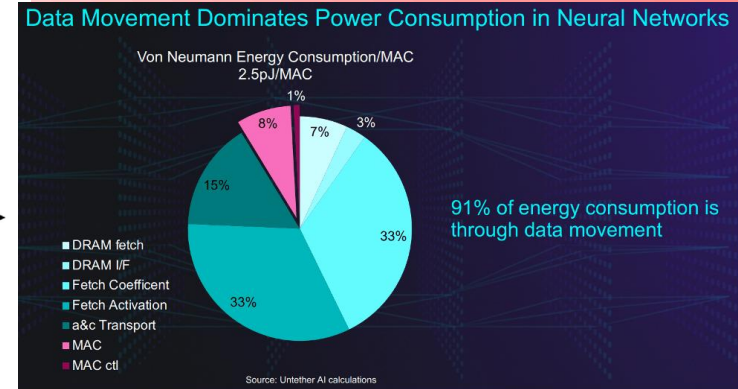
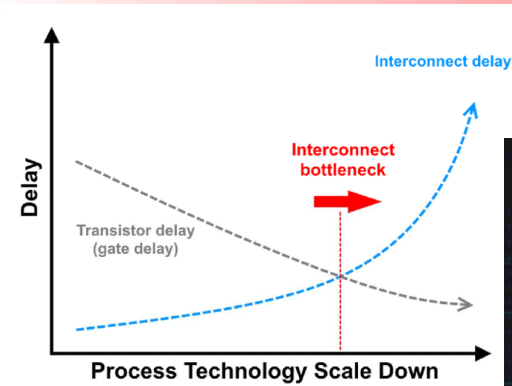

Transfer Printing μ Chiplet

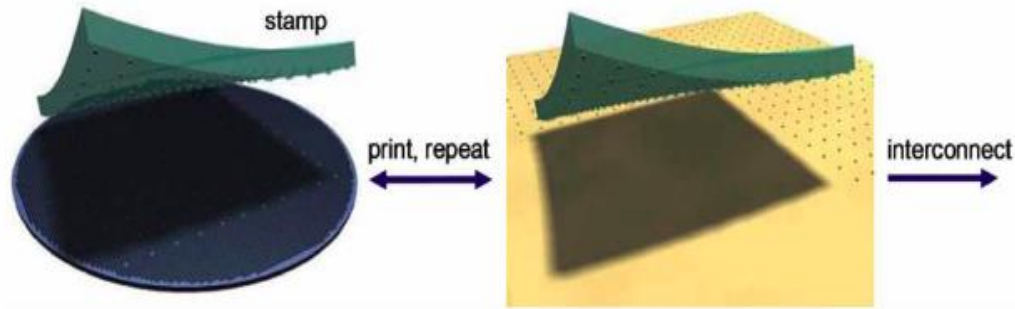

X-Celeprint

Transfer printing permits ultra small chiplets or even individual transistor 2.5/3D assembly. It delivers circuit level optimizations that one other assembly technology can.

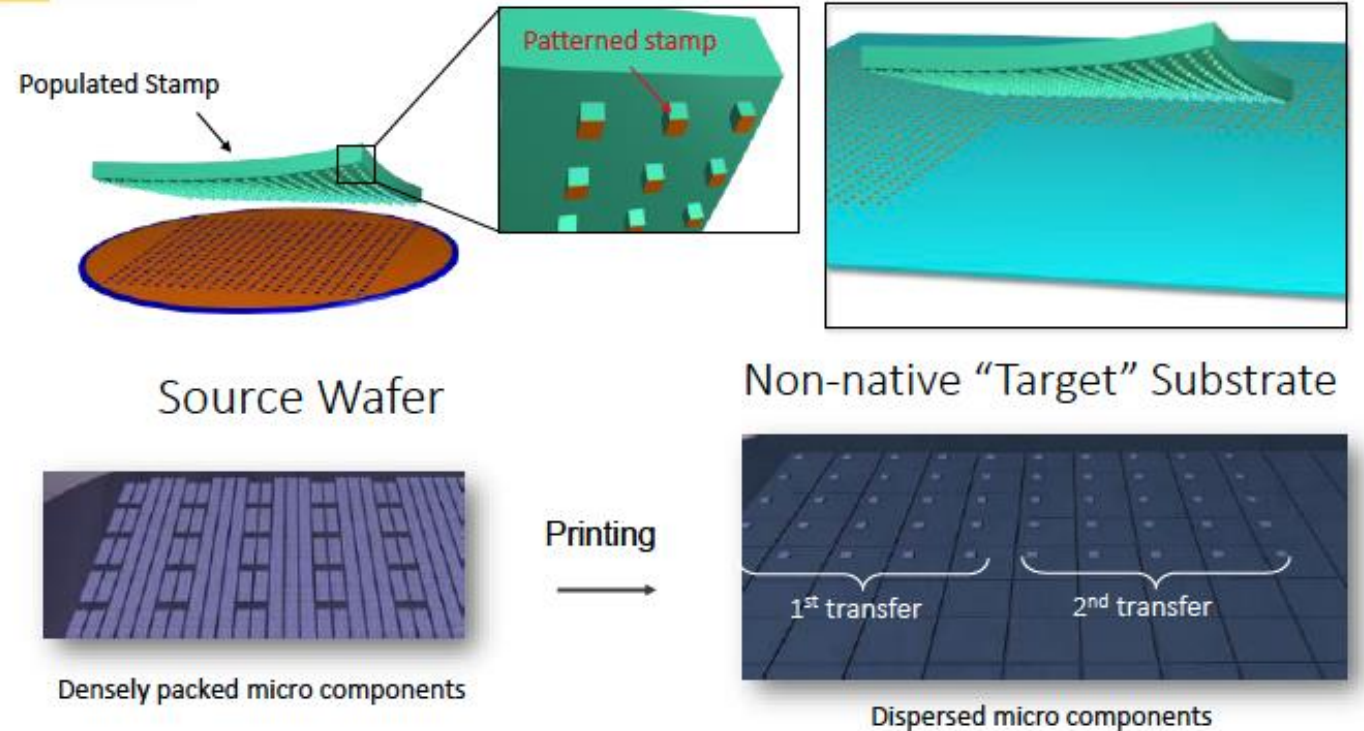

Embedded 2.5/3D — Wafer Reconstitution

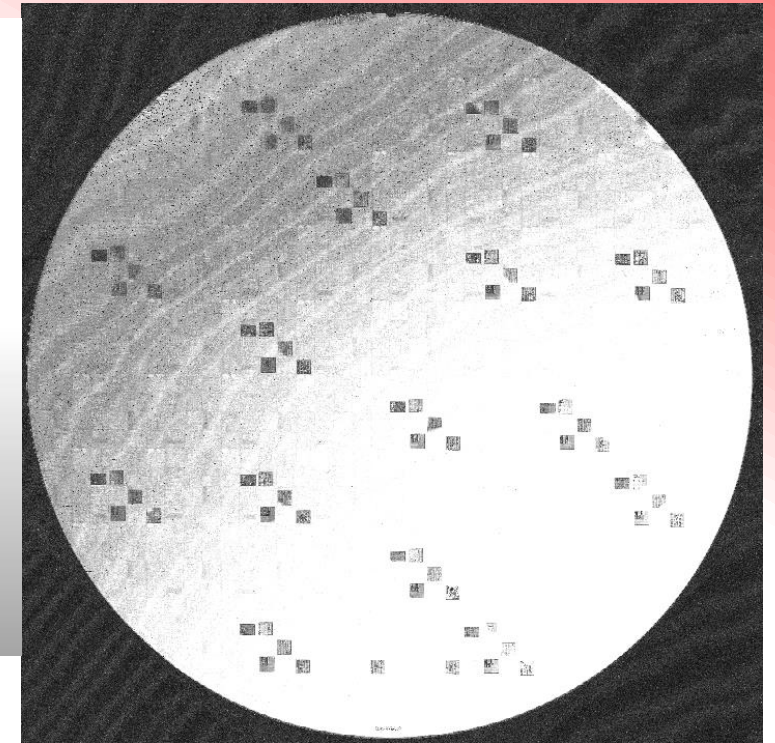
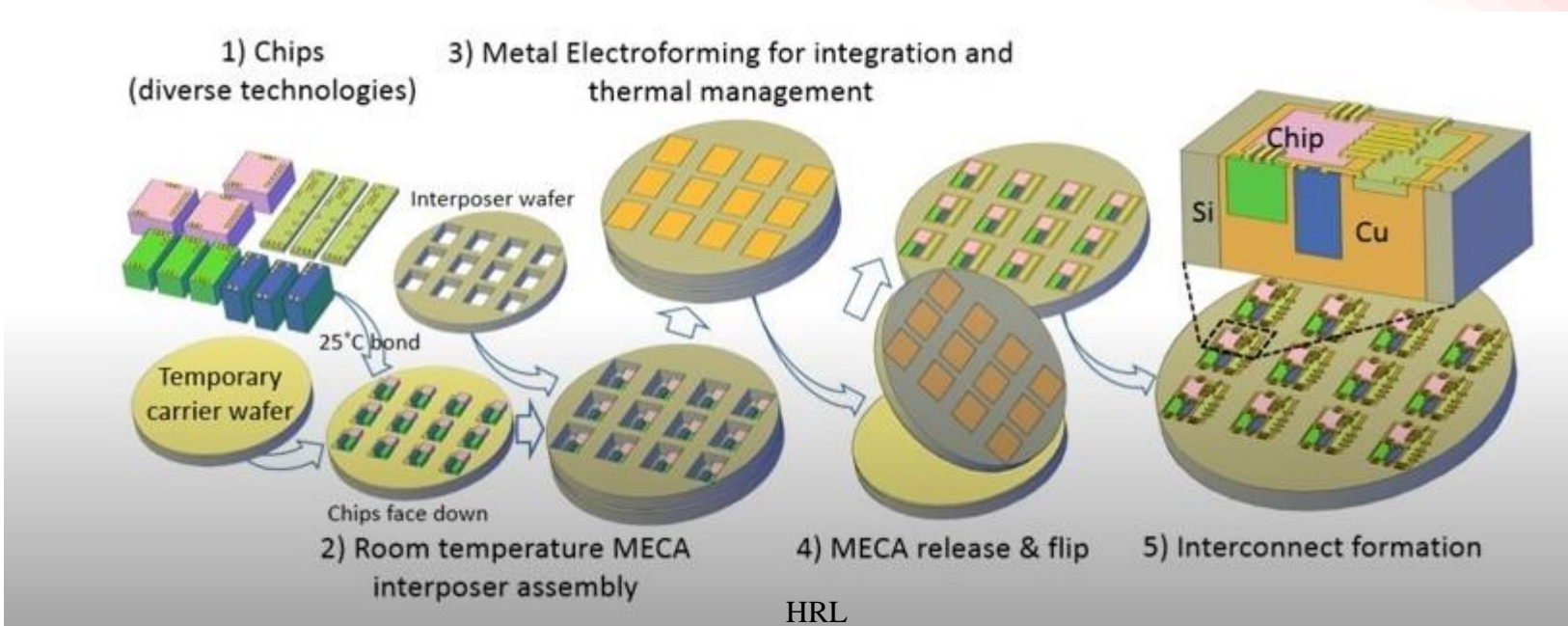

Wafer reconstruction and adaptive substrates provide additional flexibility and next level packaging alternatives.

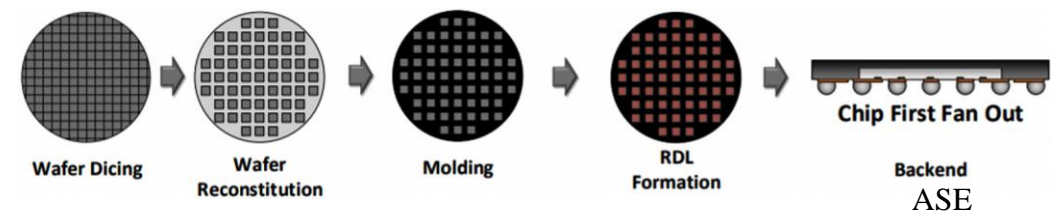

More Than Moore Technologies

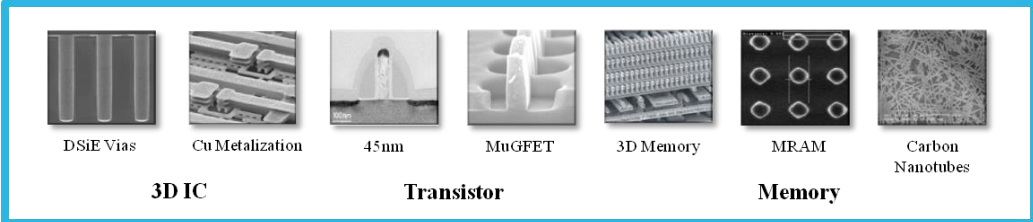
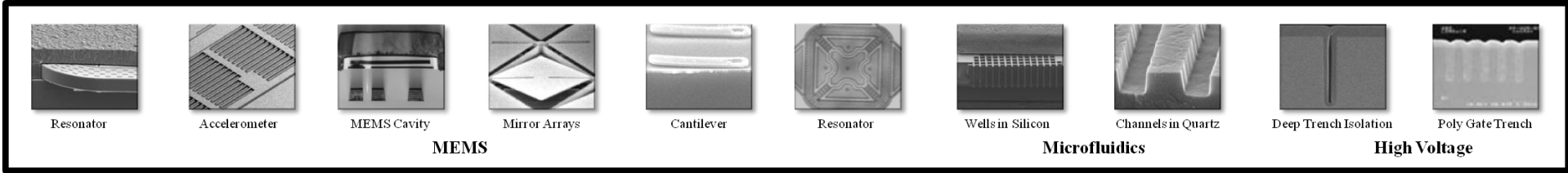
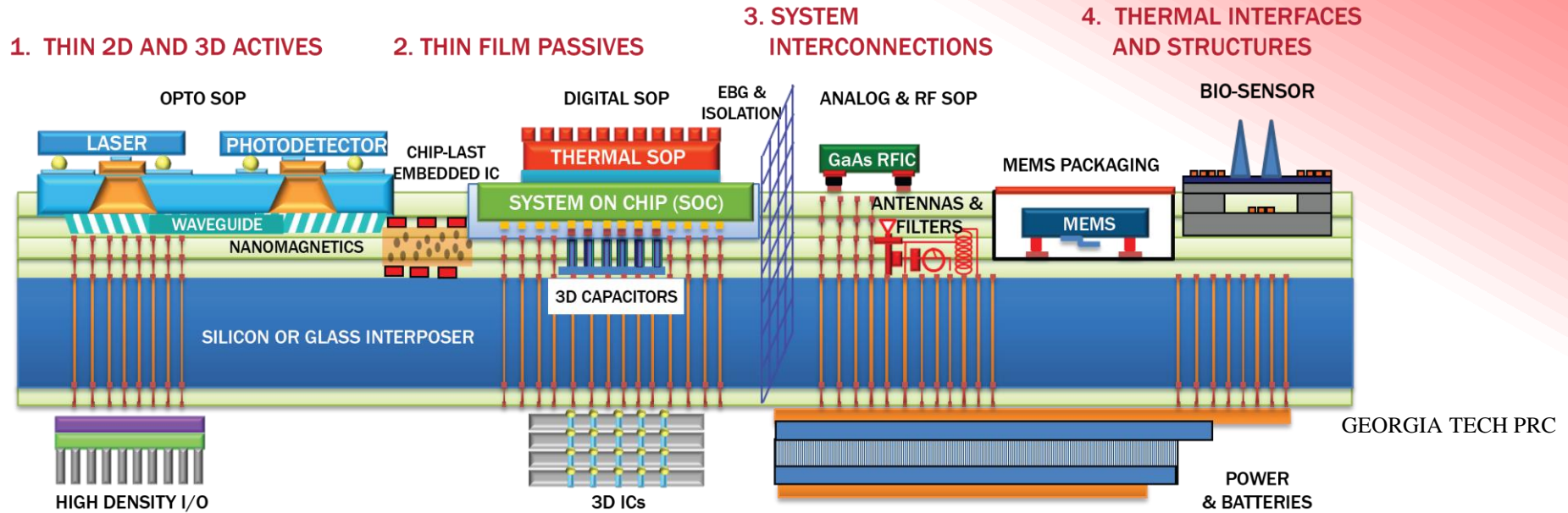

AP Components: Chiplets

- Best of Class Everything
- Easy retargeting
- Lower risk
- IP reuse
- Lower cost

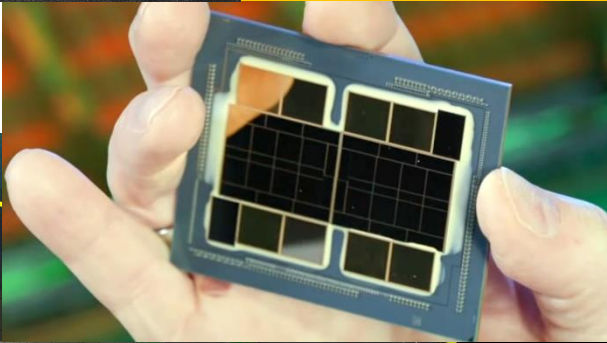
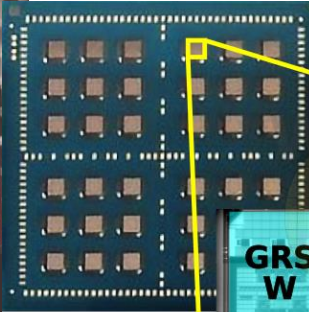
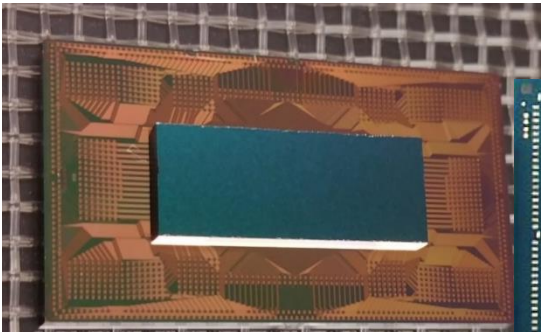
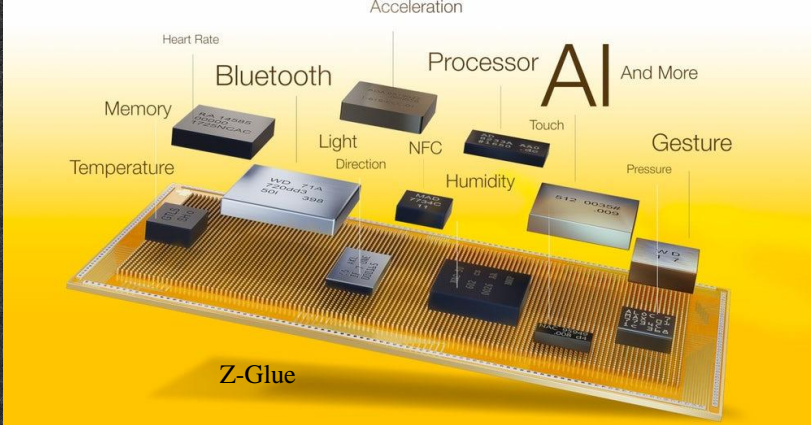
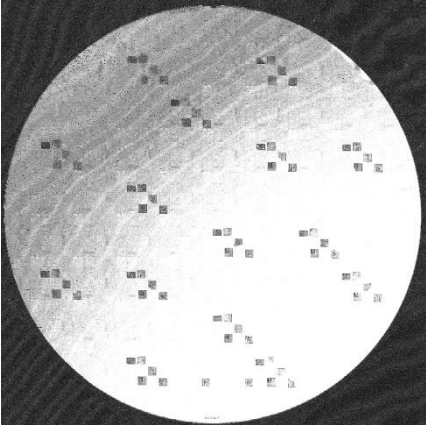

Intel

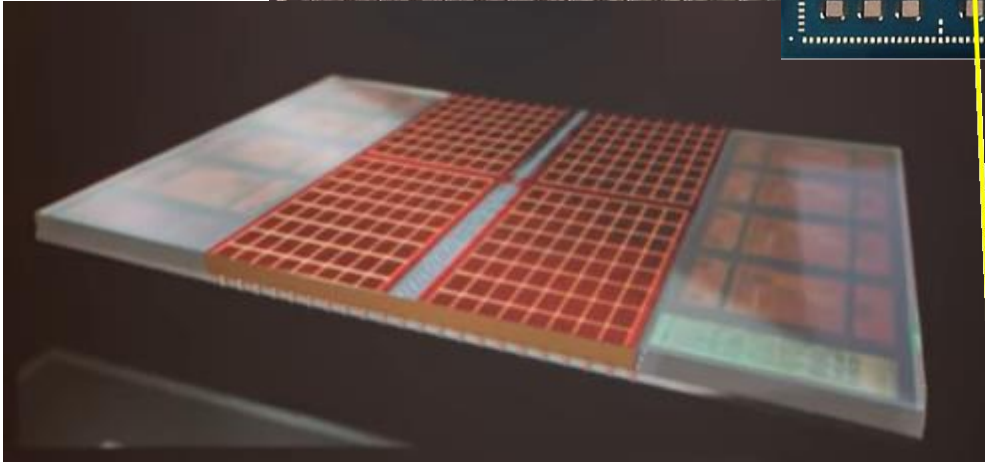

AMD

GRS W	GRS N	GPIO	GRS N	GRS E
GB	PE	PE	PE	PE
RISC-V	PE	PE	PE	PE
	PE	PE	PE	PE
	PE	PE	PE	PE
GRS W	GRS S	JTAG	GRS S	GRS E

nVidia



Intel



AP Components Micro-Connections and 3D Structures

MEMS + Precision Electronics

IIC



Bacteria-World

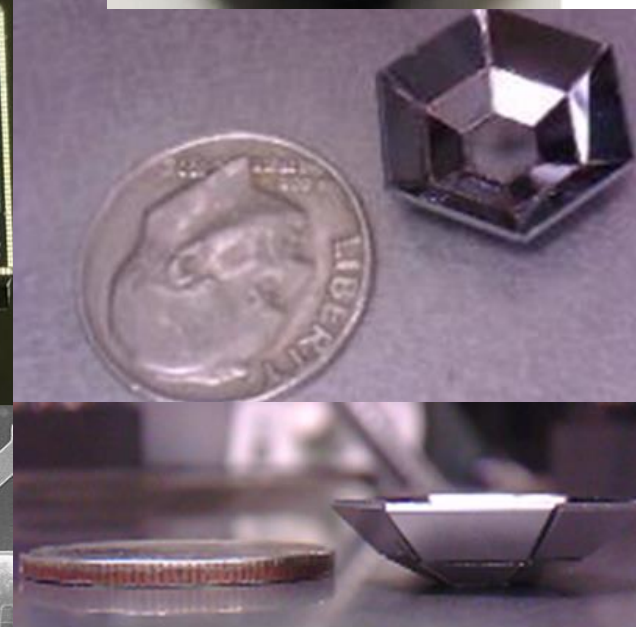
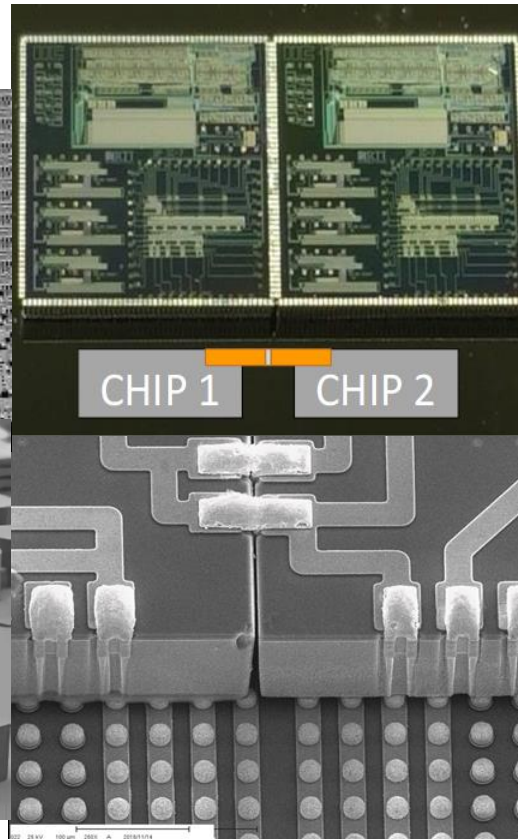
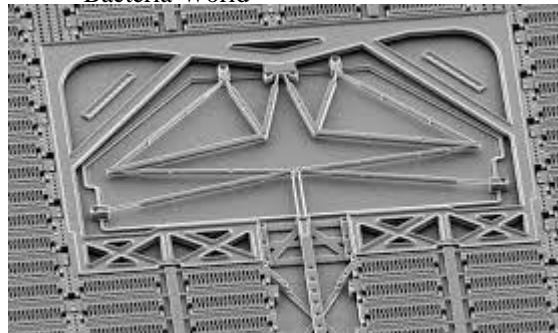

(top left) Quilt Packaging concept cross-section illustration & image of a post-reflowed QP CMOS quilt; (bottom left) SEM image of quilted chip-to-chip seam of >10 micron width; (top right) QP-enabled miniature curved array demonstration article; (bottom right) profile view of QP-enabled miniature curved array.

techunwrapped.com

AP Components: Microfluidics and Cooling

Chip Scale Cooling For Ultra-Dense Electronics

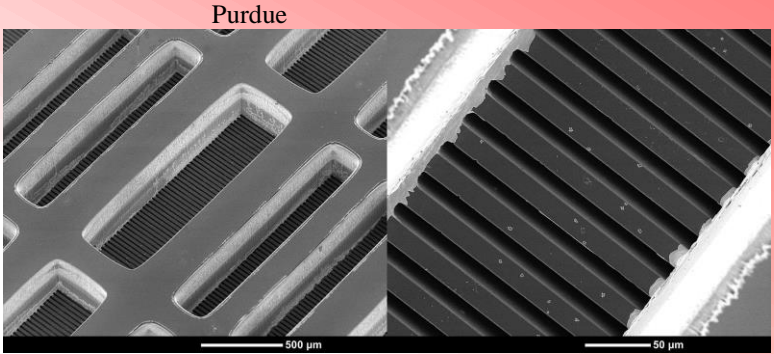

Biology + Electronics

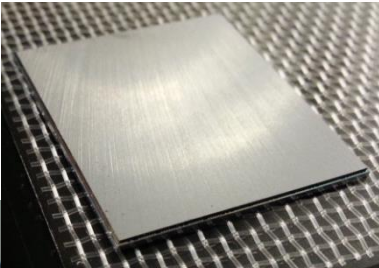
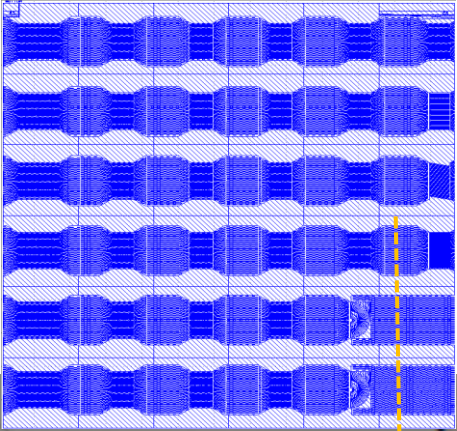
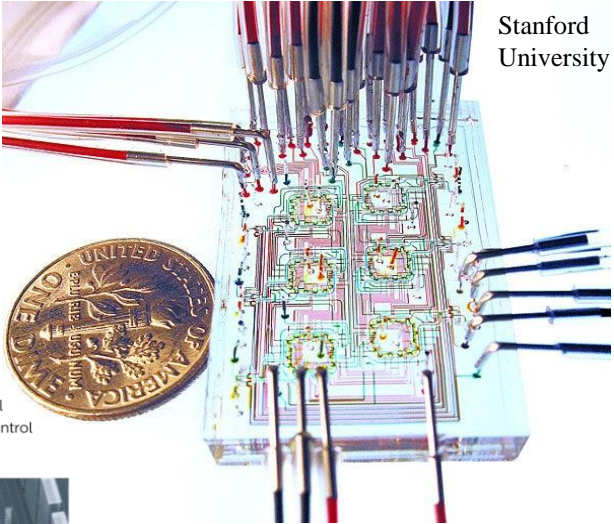

Our state-of-the-art tool set enables us to create microfluidic structures with accurate control:

- <5 degree slope control
- Sub-μm feature size control
- μm range feature size

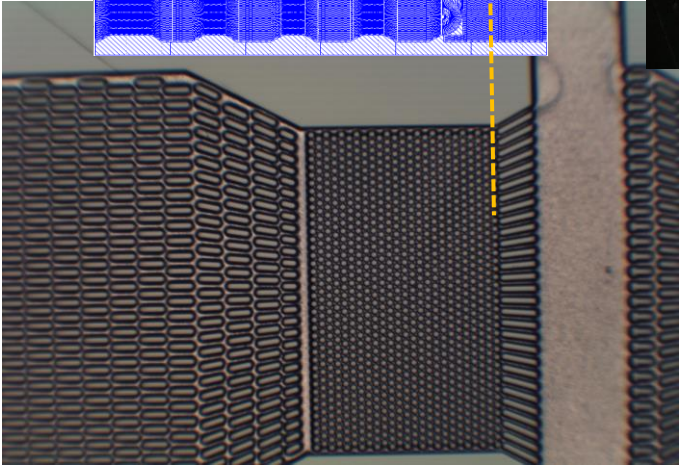
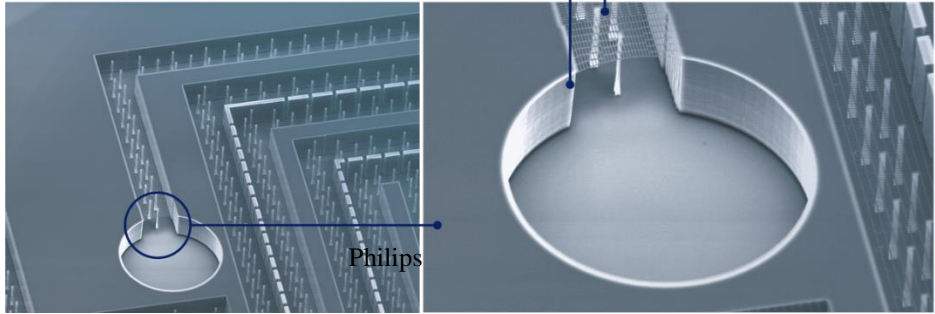

AP Components: Photonics & Quantum

- I/O

- Tb/s, $\ll 100\text{fJ/b}$

- SiP 500ff I/O Load
 - 2.5D 25ff I/O Load
 - 3D 3ff I/O Load

- Processing

- “Quantum Leaps”

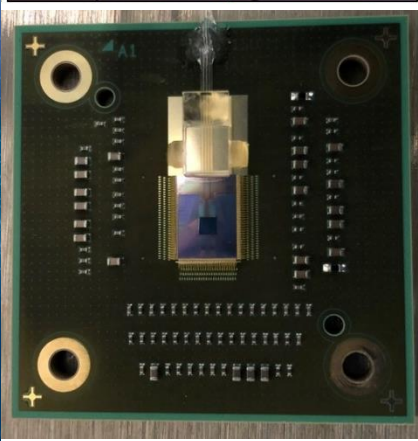
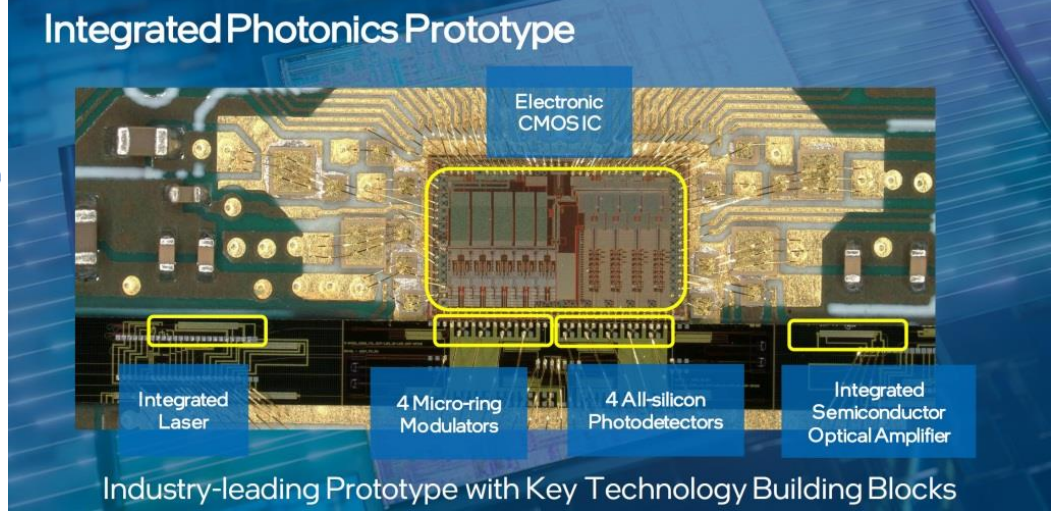
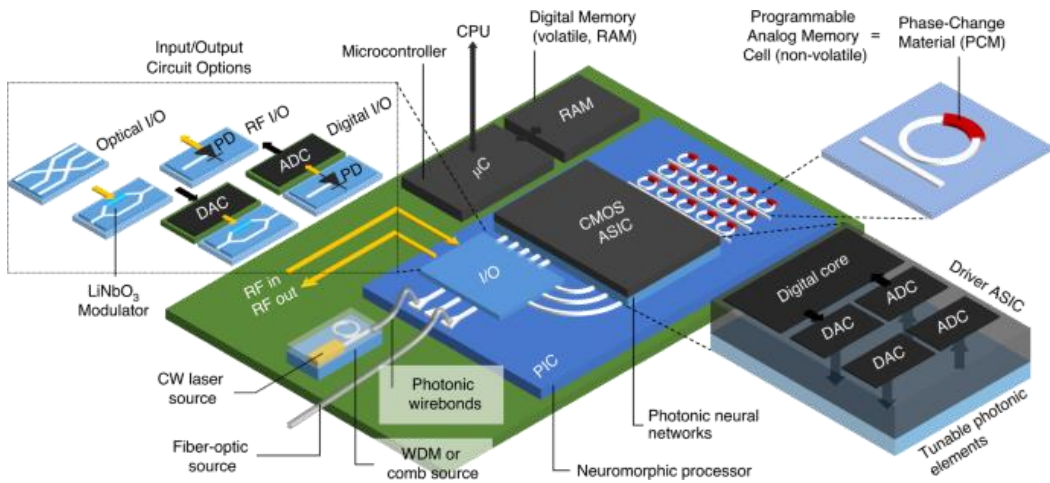
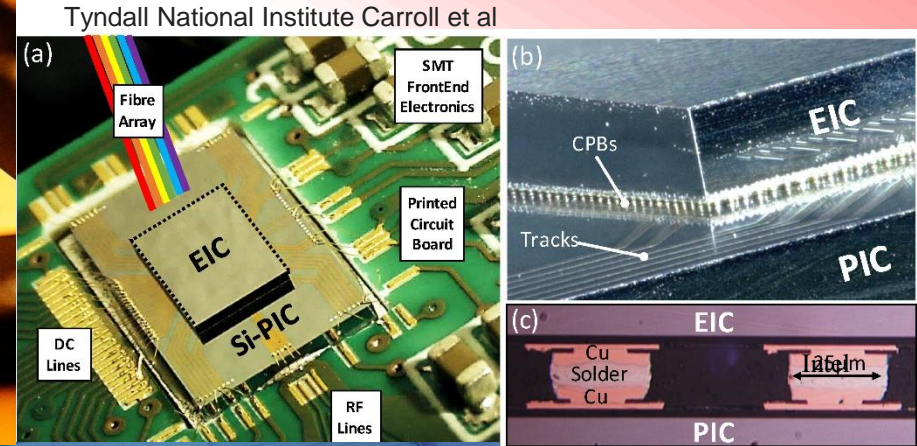
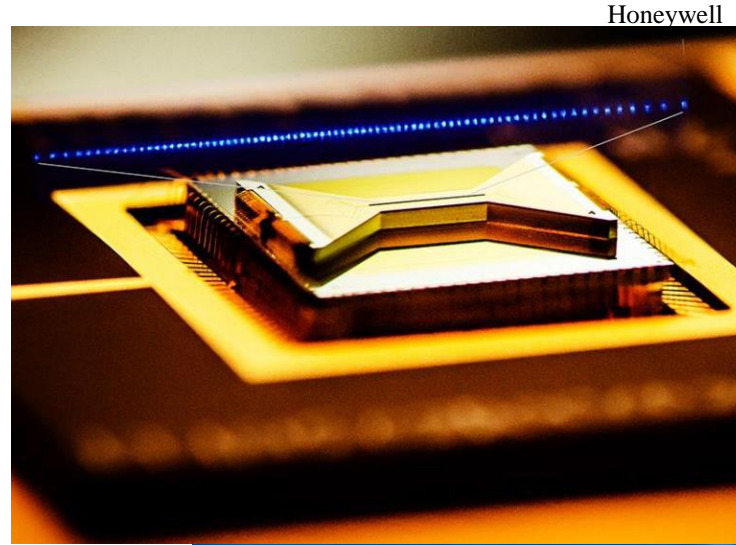

Nature 29 January 2021 Shastri

Intelligent Sensors and Edge Compute

- Communication is limited
 - Data movement costs power
 - Data movement costs time
 - Data movement costs money
 - You can't always "phone-home"

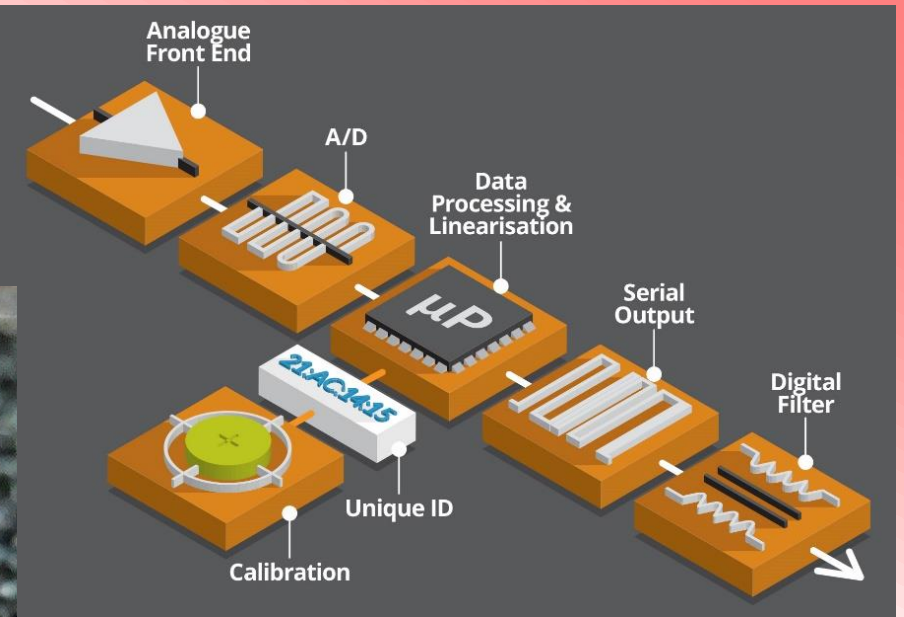
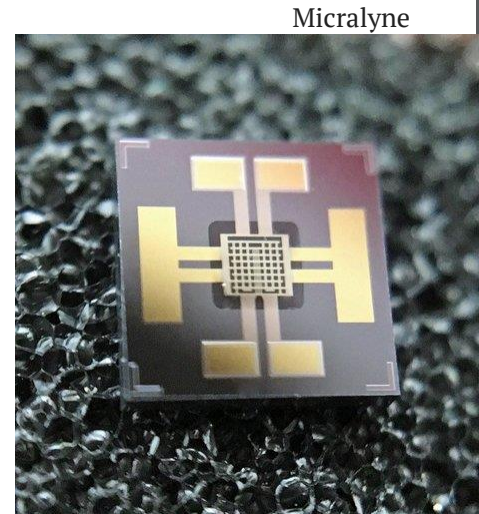

tek-troniks

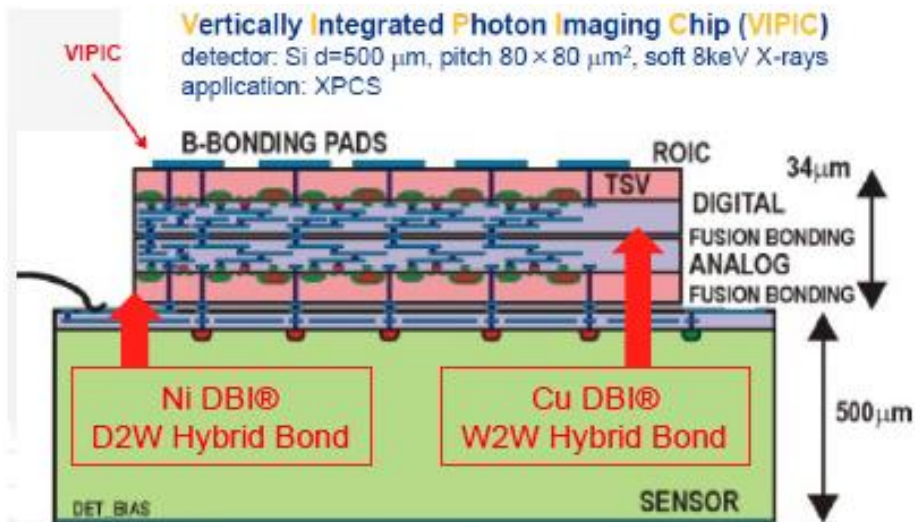

FermiLab

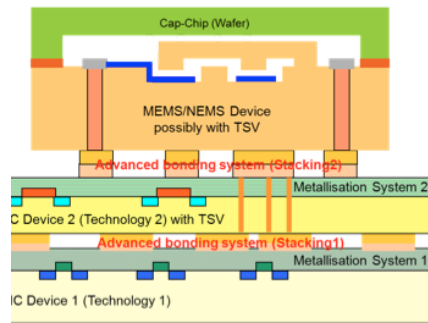

3DinCites

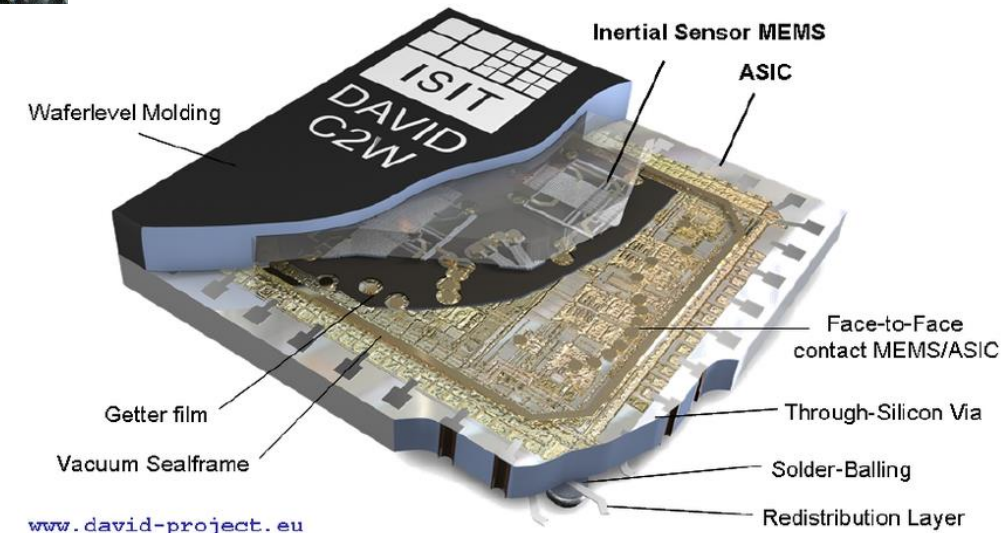

www.david-project.eu



Co-Design and Multi-Physics

- Multi-Dimensional Tools
 - Scale
 - Nanometers to centimeters
 - Electrical
 - Power
 - Signal Integrity
 - Heat
 - Mechanical
 - CTE
 - Modulus
 - Cost
 - Photonics
 - MEMS
 - Liquids



Janus Henderson

NHanced NC Facilities

The NHanced R&D fab has extensive experience in process development and prototyping, including 2.5D and 3D manufacturing and the use of exotic materials. Its skilled staff has an admirable record of successful projects and a good working relationship with the Naperville design team.

Site capabilities:

- 25,000 sq ft facility
- 7,000 sq ft clean space (class 100)
- In-house 2.5D/3D technology development
- In-house 2.5D/3D IC prototyping
- Diverse team of engineers and tools to allow operation flexibility
- 100mm, 150mm, and 200mm wafer processing
- Fab processes include photo, etch, metalization, dielectrics, bonding, wafer thinning, and CMP
- Wafer-to-wafer and chip-to-wafer bonding
- ITAR
- ISO 9001-2015
- DMEA TRUST CRADA

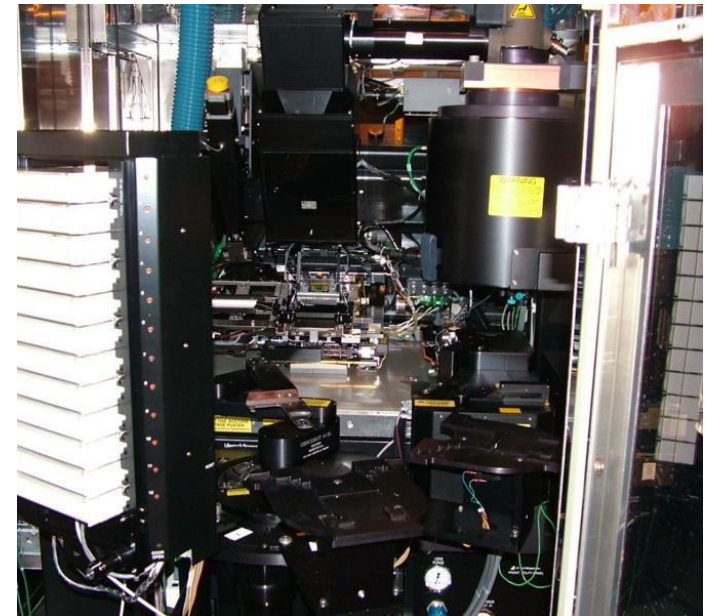
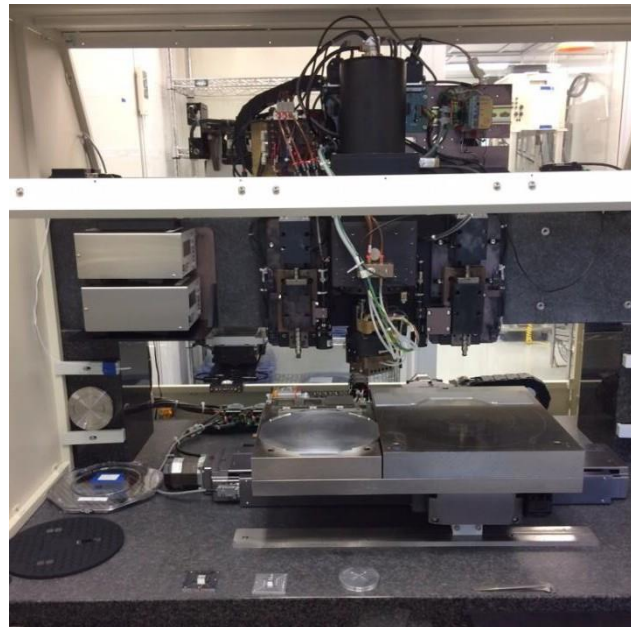

NHanced Small/Medium Scale – High Touch Manufacturing

- 2.5/3D Advanced Packaging
- Si Sensors
- Commercial Development
- Mil-Aero Development and Manufacturing
 - Full BEoL
 - Niche BEoL Processes
 - Cu, Ni, Al, +
 - Split-Fab
 - High k-caps
 - ReRAM
 - 3/5 and LiNbO3 integration
 - Thick Wafer & Thin Wafer Processing
- CRADA in place for Trust
- Target market is customers needing 1 to 1000 wafers per year

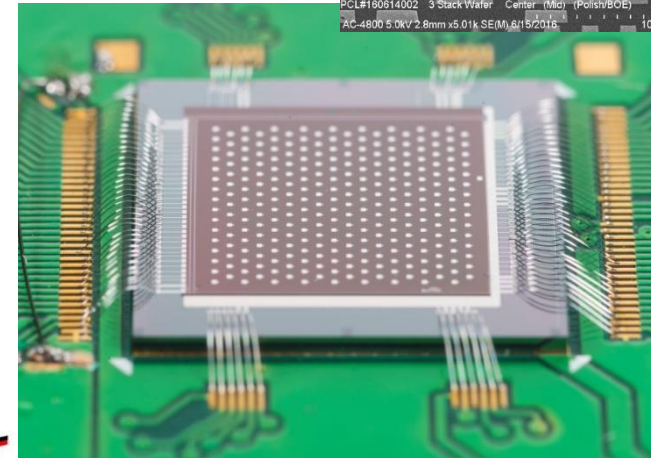
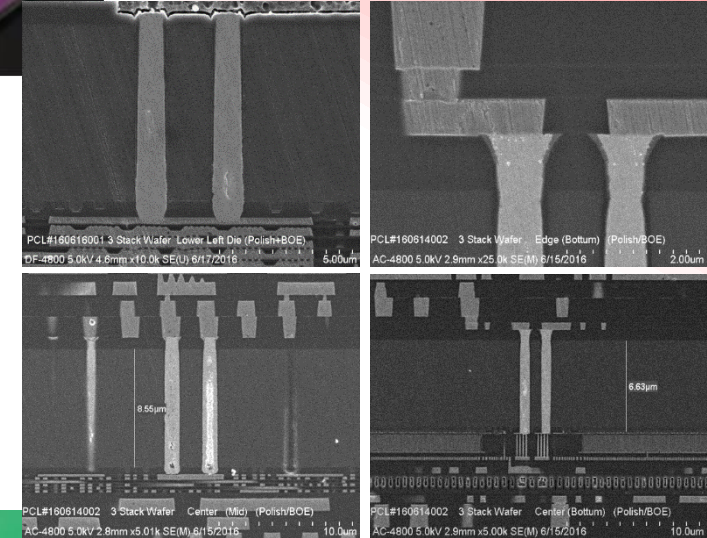
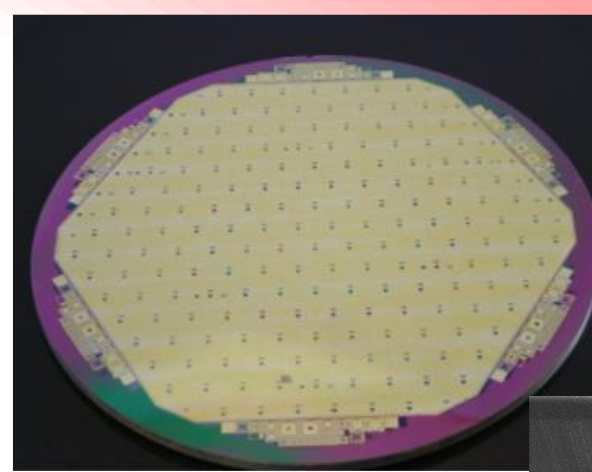



Introducing A New “Commons” Manufacturing Model Cooperative Manufacturing Partnership

NHanced, acting as the managing partner and a neutral entity among foundries and customers provides BEoL and Advanced Packaging services.

The new NHanced WestGate Foundry broke ground in Nov 2022 and first wafer out will be in 2H24. The fab capacity will be ~5,000 wafer starts per month or about 50x the existing NC fab.

**WESTGATE 1
FAB 1
151,000 sf**

**WESTGATE 2
FAB 2
175,000 sf**

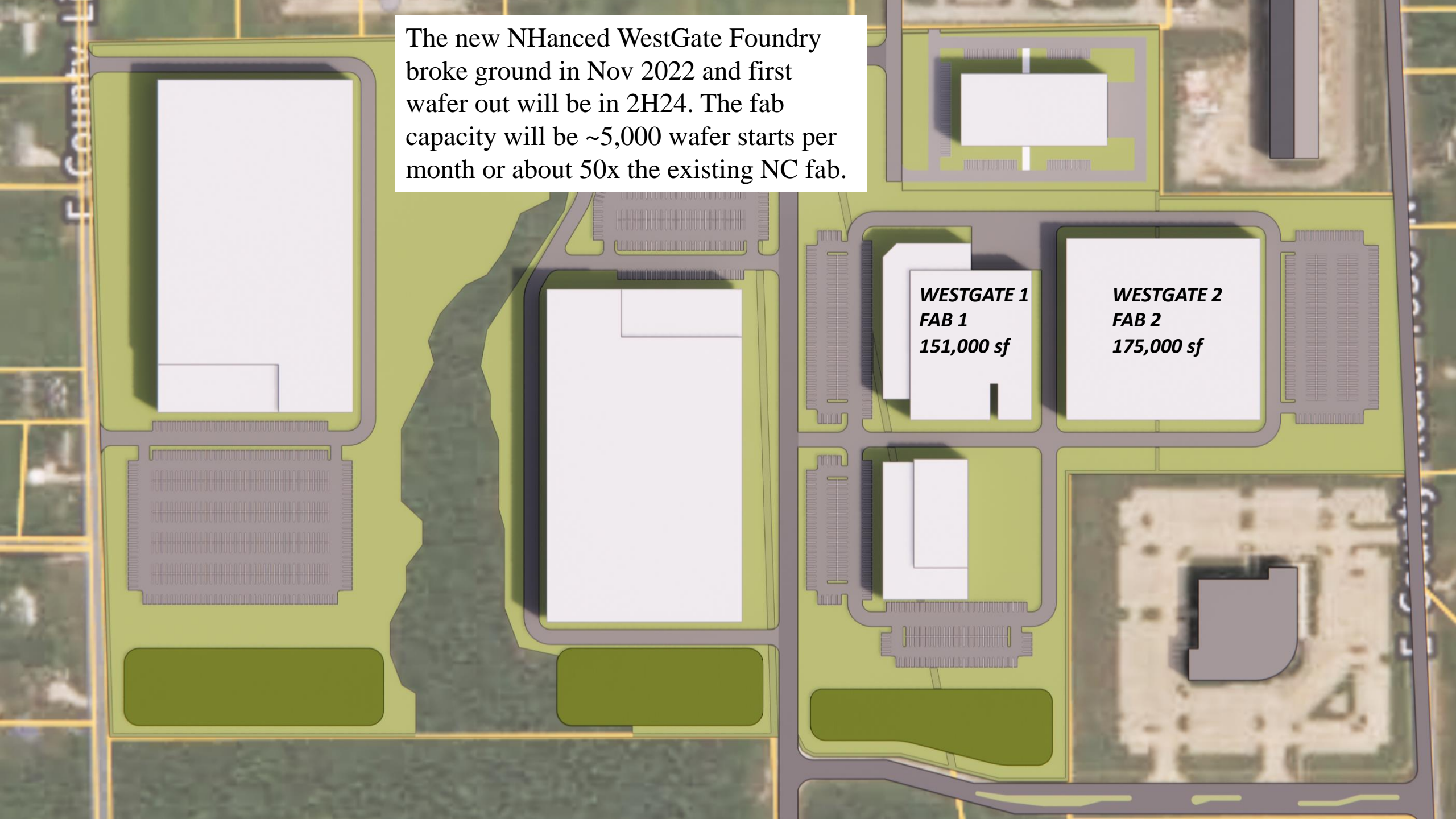

WestGate Capabilities

BEoL processing:

- Adding memory (e.g. MRAM, ReRAM)
- Copper interconnect (45nm L/S)
 - Trusted split fab
 - Secure Interconnect
- RF and power embedded passives
- Full support for 200mm, 150mm, and 100mm

Specialized base materials:

- Interposers: silicon, glass, and fused silica
 - Optical and electrical interconnect
- Advanced substrates: silicon, GaN, GaAs, InP, GaSb, LiNbO₃, SiC, etc.

Phase 2 support:

- 300mm wafer size
- 193i BEoL – Copper interconnect (12/16nmL/S)
- Built-up substrates

Advanced packaging:

- HDI Edge packaging
- Chiplets
- TSV insertion
- Covalent oxide bonding
- Hybrid copper and nickel bonding
 - True heterogenous integration
- Transfer printing assembly
- Wafer reconstitution
- Die-to-die, die-to-wafer, and wafer-to-wafer 2.5D and 3D integration
- Copper pillars
- Wire bonding
- Photonic assembly
- Solder bumping
- Flipchip assembly



Summary – The Road Ahead

- System level Moore's Law future
- Advanced Packaging is driving an industry revolution
 - Enablement of Next Generation Semiconductors
- Advanced Packaging has SWaP+++
 - Ultimately driven by economics

